

Shively Labs[®]

Circularly Polarized FM Broadcast Antenna

Model 6810



Instruction Manual
Installation, Operation, &
Maintenance

Congratulations!

Thank you for purchasing one of the finest FM broadcast antennas on the market today. The Shively Labs Model 6810 is widely recognized as the top-of-the-line in its class for its superior performance and durability.

Your purchase is backed by the best technical support in the industry. Shively is a leading manufacturer in the broadcast industry, providing an extensive range of antennas, transmission line and components. Our technical staff has a wealth of experience in the broadcast industry and is standing by to serve you in any way.

This manual is intended to give you a good basic understanding of your antenna: its proper and safe installation, startup, and operation, and troubleshooting and maintenance information to keep it working satisfactorily for years to come. *Please have everyone involved with the antenna read this manual carefully, and keep it handy for future reference.*

Meanwhile, please feel free to contact your sales representative at Shively Labs at any time if you need information or help. Call or write:

Shively Labs®

A Division of Howell Laboratories, Inc.

Bridgton, Maine 04009 USA

188 Harrison Rd., P. O. Box 389, Bridgton, Maine 04009 USA

(207) 647-3327

1-888-SHIVELY

24-hour (207) 329-5118

FAX (207) 647-8273

sales@shively.com

www.shively.com

An Employee-Owned Company

ISO 9001:2000-Certified

Publication No. IM6810 (120117)

IMPORTANT

Please read this manual in its entirety before beginning installation of your antenna!

Failure to follow the installation and operation instructions in this manual could lead to failure of your equipment and might even void your warranty!

Table of Contents

List of Illustrations	ii
List of Tables	ii
Chapter 1 Precautions and Preparation	1
Precautions	1
Receiving	1
Unpacking	1
Checking the system	2
Chapter 2 Antenna Installation.....	3
Precautions	3
Study your antenna.....	3
Install the back support mounts	4
Install the bay radiators.....	5
Install standard radomes (if applicable)	7
Install XXL radomes (if applicable)	9
Installing the feedline assemblies on the tower	14
Installing the transformer	17
Installing parasitic elements (if applicable)	17
Chapter 3 De-Icer Installation (if applicable).....	19
De-icer description	19
Before beginning de-icer installation.....	19
Installation procedure	20
Chapter 4 Startup and Operation.....	27
Precautions	27
Pressurization	27
Impedance trimming	30
System sweep (recommended)	31
Checkout.....	31
Antenna operation	32
De-icer system operation.....	32
Chapter 5 Maintenance	33
Precautions	33
Maintenance log	33
Physical inspection	33
De-Icer check	34
Paint	34
Radiator removal for repair	34
Return policy	34
Troubleshooting.....	34
Sample maintenance log.....	37

List of Illustrations

Figure 1	Attach the back support mount	4
Figure 2	Attach bay radiator.....	6
Figure 3	Flange hardware tightening sequence.....	7
Figure 4	Standard radome installation.....	8
Figure 5	XXL radome installation (radome, closure plates and ground straps)	11
Figure 6	XXL radome installation (backplate and bay radiator).....	12
Figure 7	XXL radome installation (tower mounts)	13
Figure 8	Common feedline mount configurations	15
Figure 9	Feedline flange detail	16
Figure 10	Transformer Installation, top view	17
Figure 11	De-icer system schematic diagram, overall.....	21
Figure 12	Bay junction box installation	22
Figure 13	Shively de-icer control box layout.....	23
Figure 14	Pressurized gas schematic	28
Figure 15	Impedance-matching transformer	30

List of Tables

Table 1	Torque specifications, flange bolts.....	7
Table 2	De-icer specifications	24
Table 3	Single thermostat readings	24
Table 4	Tandem thermostat readings	24
Table 5	Volume of coax per 1000 feet of length	29
Table 6	Factory control rod settings	30

1

Precautions and Preparation

Precautions

WARNING

Don't expose personnel to the medical hazards of intense radio frequency (RF) radiation. Whenever working on the tower in the area of the antenna, turn off all transmitters and lock them out so that they cannot be turned on accidentally.

For reference on RF safety, see CFR 29, Section 1910.97, the OSHA standard for exposure to non-ionizing radiation.

Receiving

As soon as you receive your antenna, *BEFORE* signing for the shipment:

- a. Check to be sure all the material has arrived.

NOTE

The box number and the total number of boxes are marked on each box; for example, "Box 2 of 5" means "box number 2 of a total of five boxes."

- b. Check for evident damage to any of the boxes.
- c. If any boxes are missing, or if any are obviously damaged, describe the problem in a WRITTEN note on the shipping papers BEFORE signing them. Then call Shively right away, and we'll do everything we can to correct the situation.

Important!

Never store the antenna system outdoors, boxed or otherwise. Take pains to keep the antenna components dry. You will need to purge moisture from the interior of the antenna components before applying transmitter power, and purging will be much more time-consuming if the components get wet.

Unpacking

- a. Find Box 1; it is marked "Open This Box First." It contains the transformer and two copies of the installation drawing. The parts list on one sheet of the installation drawing shows what box each item is in.
- b. Then open the boxes and examine for shipping damages. File any necessary claims with the carrier immediately.
- c. If all the boxes are present and in good condition but material seems to be missing, please contact Shively Labs immediately, using the telephone or Fax number on the inside cover of this manual. For the best service, have our shop order number (S/O) handy; it's in the block at the bottom right corner of the installation drawing.
- d. Along with your antenna you will get a spare parts kit. Place this in a safe place until it is needed.

CAUTION

All contact surfaces and openings to the interior of the components are protected from contamination and from physical damage by caps and plastic bags. Do not remove this protection until ready to connect the components.

Checking the system

Remember!

It is YOUR responsibility to ensure that your installation meets all applicable codes and the centerline-of-radiation requirements of your FCC construction permit.

Shively has planned the installation of the antenna based upon information provided by you. If this information contained errors, the parts and mounting hardware will have been designed incorrectly and will cause expensive delays in installation. *Therefore, we recommend that you recheck the installation parameters during this planning stage.*

Check all the parts to be sure that they will fit the tower and each other. Study the installation drawings carefully to confirm that the information used in designing the antenna and mounts was, in fact, accurate.

Have a reliable tower person, familiar with antennas and coaxial line, inspect the tower and review the installation drawings before the full rigging crew arrives.

If design problems are found, contact Shively Labs immediately. Pay particular attention to:

- Frequency of the antenna.
- Fit of the mounts to the tower members.
- Freedom from interference by gussets, leg flanges, guys and their attachment points, tower face members, obstruction lights, and other components.
- Compatibility of transmission line and antenna input terminals.
- Location of the transmission line run relative to the antenna input terminal.
- Use of non-metallic guy sections on the tower in the region to be occupied by the FM antenna. Ensure that there are no metal guys within ten feet (three meters) of any radiator.
- Availability of proper electrical service for de-icers, if applicable.
- The adequacy of the tower structure and guys to carry the windload placed upon them by the antenna, particularly if radomes are used.

You gave Shively this information at the time of purchase, but a last check at this time can catch an error, which will be easier to correct before installation begins.

Precautions

WARNING

Don't expose personnel to the medical hazards of intense radio frequency (RF) radiation. Whenever working on the tower in the area of the antenna, turn off all transmitters and lock them out so that they cannot be turned on accidentally.

WARNING

Material safety data sheets for the chemicals you may encounter are appended at the end of this manual. Study them carefully before beginning installation.

CAUTION

O-rings are made of silicone. Do not lubricate them with silicone grease, as this will soften the O-ring. Use only a light lubricating coat of O-Lube (provided) or petroleum jelly; too much may hamper electrical contact and contaminate the interior of the system.

CAUTION

Feedstrap orientation is critical to performance. In general, the feedstraps in a full-wave-spaced antenna will all be oriented the same, while those in a half-wave-spaced antenna will alternate. *Install each radiator in accordance with its stenciled bay numbers and its "up-arrow" sticker.*

Study your antenna

CAUTION

These procedures are guidelines. Assemble components exactly in accordance with the installation drawing. If you don't, the antenna may not perform as expected.

It will be easiest to mount the radiators, feedline mounts, and radomes (if applicable) onto the feedline sections before the feedline sections are mounted on the tower.

Determine what, if any, icing protection your antenna has.

If your antenna has standard radomes:

- Perform [Install the back support mounts](#) on page 4.
- Perform [Install the bay radiators](#) on page 5.
- Then go to [Install standard radomes \(if applicable\)](#) on page 7.

If your antenna has XXL radomes:

- Perform [Install the bay radiators](#) on page 5.
- Then go to [Install XXL radomes \(if applicable\)](#) on page 9.

If your antenna has de-icers:

- Perform [Install the back support mounts](#) on page 4.
- Perform [Install the bay radiators](#) on page 5.
- Then go to [Chapter 3](#) for de-icer installation.

If your antenna does not have radomes or de-icers, continue with [Install the back support mounts](#), then [Install the bay radiators](#).

Install the back support mounts

- a. Pair up the feedline sections and the radiator assemblies, using the bay number stenciled on each piece.

Important

This back support mount is NOT used with XXL radomes!

- b. Attach the back support mount to the feedline:
 - (1) Lay a feedline section horizontally, supported off the ground, with its baymount flange pointing downward.
 - (2) Study your installation drawing. There is a detail identifying the correct azimuth rotation of the antenna bays from the tower mounting surface.
 - (3) Now look at the feedline, with its upper and lower mount flanges. The upper feedline mount flange has a series of notches cut into it ([Figure 1](#)). The center notch is exactly opposite the baymount flange. Each notch represents five degrees (5°) of azimuth rotation. Align the centered mark on the back support mount to the notch representing the azimuth rotation identified on the installation drawing.

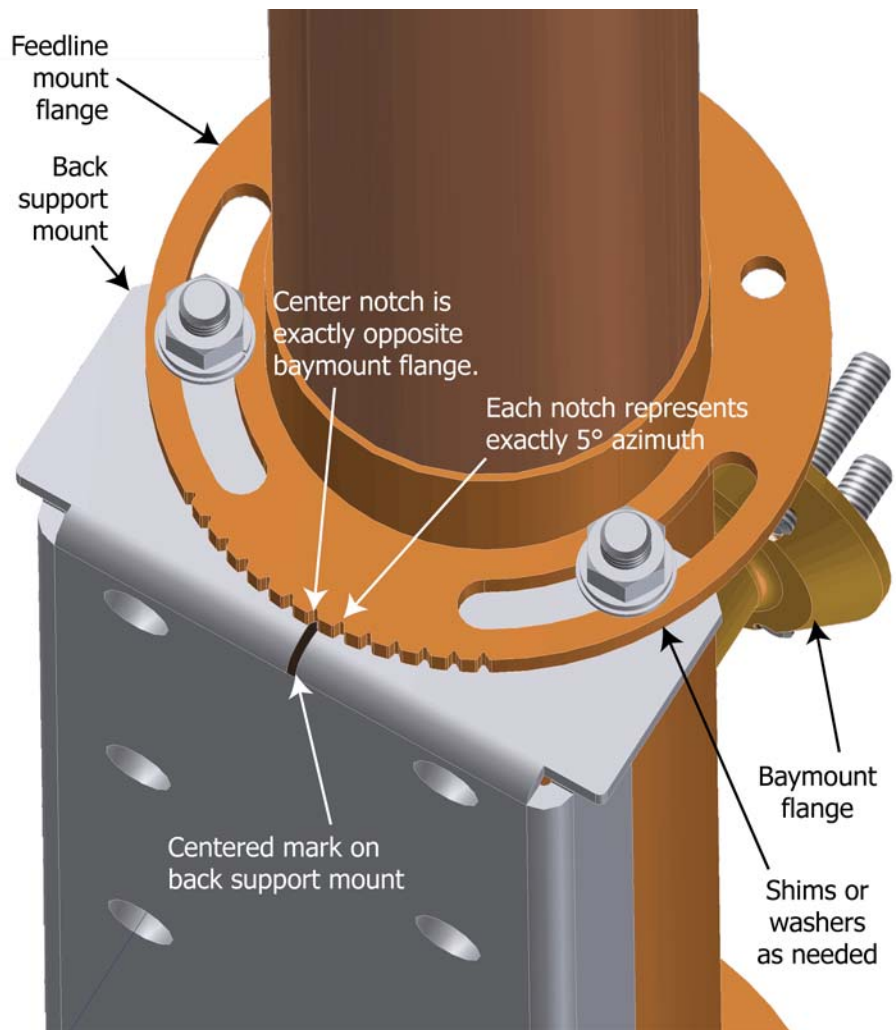

Figure 1. Attach the back support mount

Antenna Installation

- (4) Using a hardware mounting kit (four bolts with nuts and washers), secure the back support mount to the upper feedline mount flange and lower feedline mount flange.

NOTE

Use shims or washers as necessary to fit the back support mount to the mount flanges.

NOTE

You may need to save final tightening of this hardware until the feedline is installed on the tower.

- c. Repeat the above steps for the remaining feedline sections.

Install the bay radiators

Important

Be very careful not to disturb or damage the feed strap when handling the bay radiator.

- a. Attach the bay radiator to the feedline ([Figure 2](#)):
 - (1) Roll the feedline section over so that the baymount flange points upward. Secure the feedline section at the brass end, using clamps, to prevent its turning with the weight of the radiator.

CAUTION

All contact surfaces and openings to the interior of the components are protected from contamination and from physical damage by protective covers and plastic bags. Do not remove this protection until ready to connect the components.

- (2) Remove the plastic bag and protective cover from the baymount flange.
- (3) Make sure an inner conductor connector is in place in the inner conductor of the baymount flange of the feedline.

NOTE

Feedline flange hardware and O-ring are shipped separately in a plastic bag. Each bag contains the hardware and O-ring for one flange.

CAUTION

Be sure the baymount flange O-ring is properly seated in its groove and not pinched between the flange contact surfaces.

- (4) Coat the baymount flange O-ring lightly with O-Lube (supplied with the antenna), then install it in the O-ring groove in the baymount flange.
- (5) Remove the matching radiator assembly from its protective plastic bag.

CAUTION

Be sure the radiator's inner conductor fits cleanly over the baymount's inner conductor connector. If any of the fingers of the connector are forced outside the radiator's inner conductor (we call this a "split bullet"), this will cause arcing and damage to the antenna.

- (6) Align the radiator with the baymount flange as shown, with the top of the radiator pointing toward the top of the feedline. Carefully place the radiator into position over the flange studs and inner conductor connector.
- (7) First snug the baymount flange hardware, then tighten in the sequence shown in [Figure 3](#). Torque in accordance with [Table 1](#) on page 7.

Antenna Installation

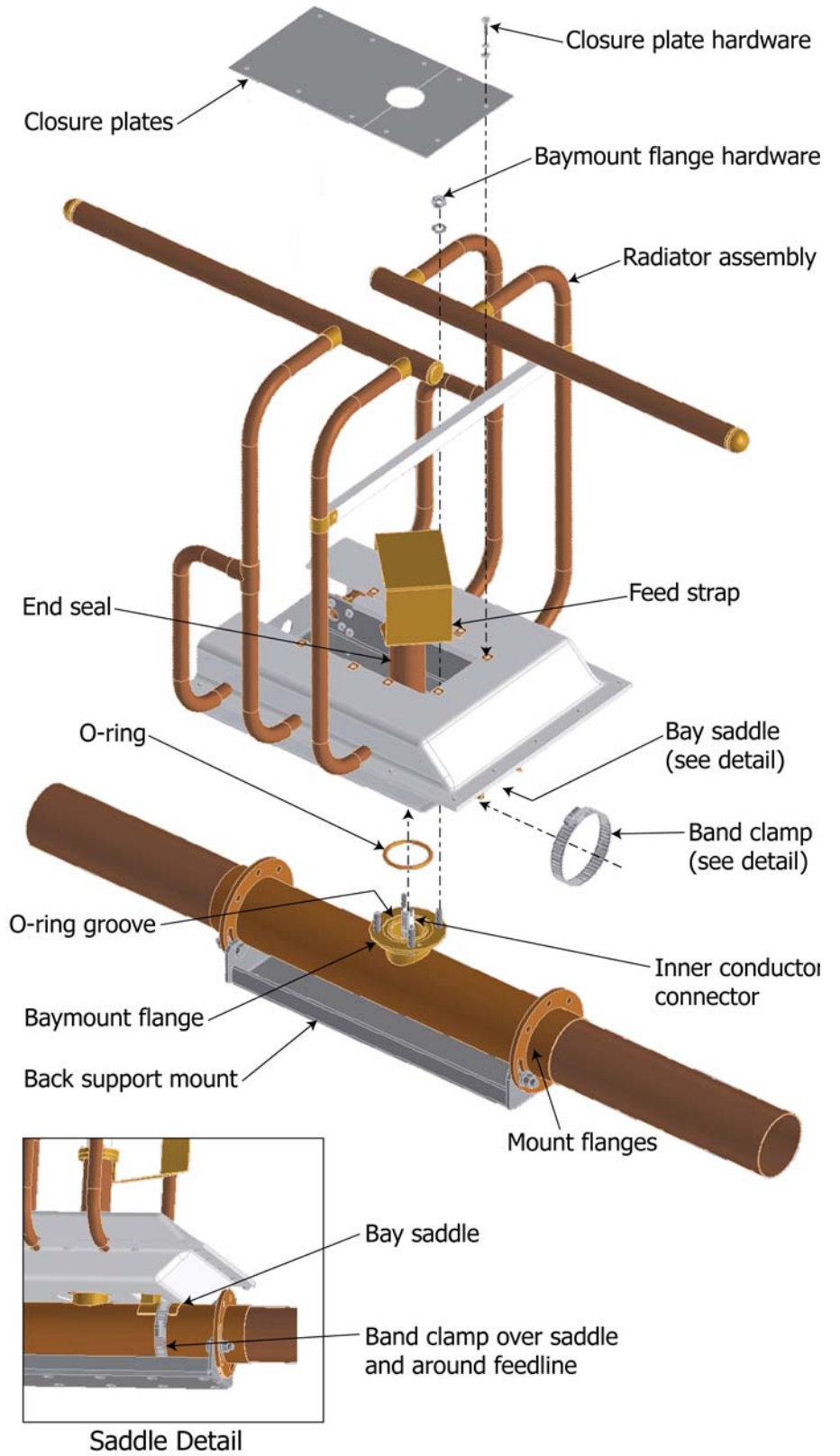

Figure 2. Attach bay radiator

Antenna Installation

- b. Clamp the mounting saddle to the feedline, using a band clamp.
- c. The partial radome closure plates are shipped separately. Install them over the end seal, using the hardware provided.
- d. Repeat the above steps for the remaining feedline sections.

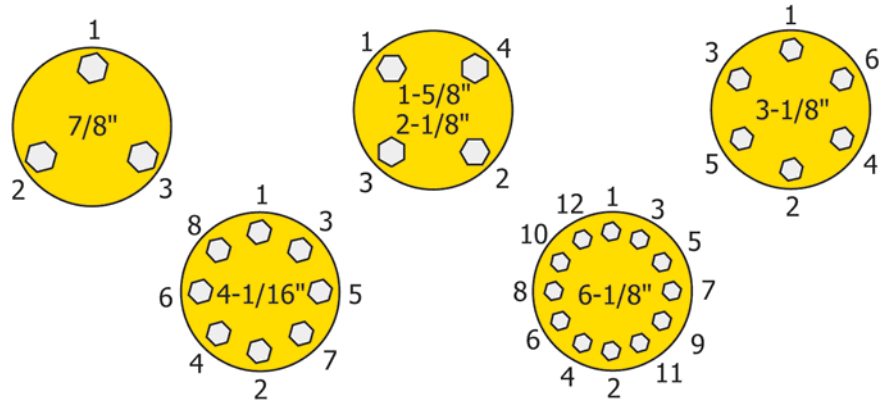

Figure 3. Flange hardware tightening sequence

Table 1. Torque specifications, flange bolts

Transmission Line Size	Bolt Size	Torque	
1-5/8"	5/16-18	10 ft-lb	13 N-m
2-1/8"	3/8-16	16 ft-lb	23 N-m
3-1/8"	3/8-16	16 ft-lb	23 N-m
4-1/16"	3/8-16	16 ft-lb	23 N-m

Install standard radomes (if applicable)

If your system includes standard radomes, you can most easily install them on the ground following completion of [Install the back support mounts](#) and [Install the bay radiators](#). See [Figure 4](#) on page 8.

NOTE

Radome match-markings bear no relation to radiator and feedline markings. Install any radome on any bay.

Radome halves are match-marked in pairs (A-A, B-B, etc.). In order to align the flange bolt holes, be sure to pair them according to their match-markings.

- a. Select a pair of radome halves match-marked with the same letter designation (A and A, B and B, etc.). The top (1) and bottom (2) radome halves include the radome-mounted halves (3) and (4) of the radome mounting brackets.
- b. Open the hardware kit. The kit contains:
 - hardware (5), 1/4-20, for the radome flanges,
 - hardware (6) to join the radome mounting bracket halves, and
 - hardware (7) to secure the mounting brackets to the feedline mount flange (8),
 - the flange-mounted halves (9) and (10) of the mounting brackets.

Antenna Installation

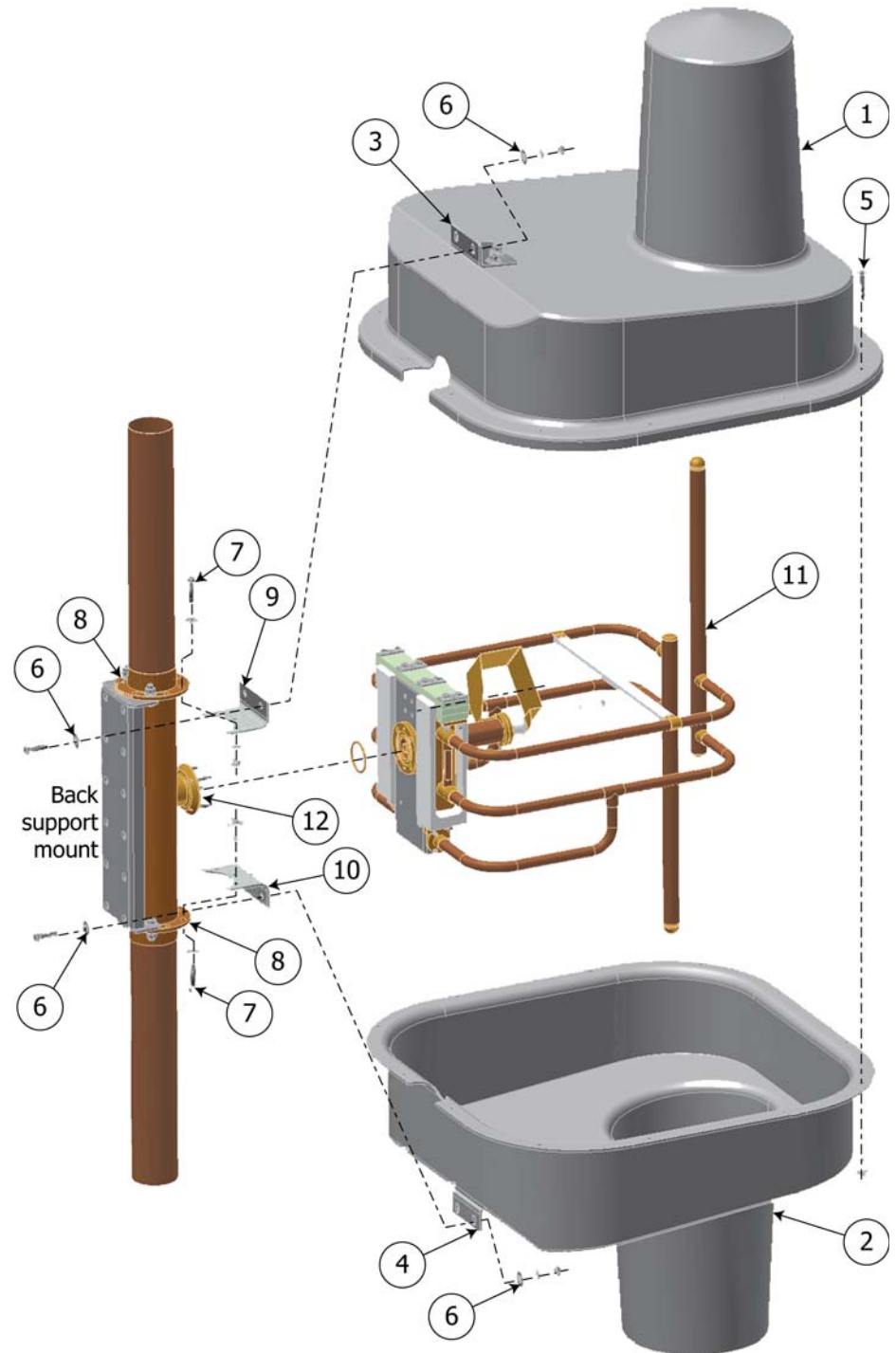

1	Top radome half	7	Bracket mounting hardware
2	Bottom radome half	8	Feedline mount flange
3	Top radome bracket	9	Top radome bracket
4	Bottom radome bracket	10	Bottom radome bracket
5	Radome flange hardware	11	Bay radiator
6	Radome bracket hardware	12	Baymount

Figure 4. Standard radome installation

Antenna Installation

- c. Identify the top radome half (1) by its wide, overlapping mating flange and the bottom radome half (2) by its narrow mating flange and drain holes.
- d. Install the top radome half:

NOTE

Each radome half has a double notch under the mount; the larger outer notch fits over the feedline and the smaller inner notch fits against the baymount.

- (1) Carefully place the top radome half in place, slipping it behind the radiator (11) and up against the baymount (12).
 - (2) Loosely attach the flange-mounted bracket half (9) of the top radome mount to the feedline mount flange (8).
 - (3) Loosely install the hardware (6) to secure the mounting bracket halves together.
- e. Install the bottom radome half:
 - (1) Carefully place the bottom radome half (2) in place, slipping it behind the radiator (11) and up against the baymount (12), with its flange inside the larger flange of the upper radome half.
 - (2) Loosely attach the flange-mounted bracket half (10) of the bottom radome mount to the feedline mount flange (8).
 - (3) Loosely install the hardware (6) to secure the mounting bracket halves together.

NOTE

You may have to squeeze the radome flanges together slightly with a clamp to start the nuts. Get all these nuts and bolts in place before tightening them.

- (4) Fasten the two radome halves together loosely with the radome flange hardware (5), starting near the feedline and working around both sides to the outer edge. It may be necessary to squeeze the radome flanges together to start the nuts.
- f. Once all hardware is in place, tighten all hardware securely.
 - g. Seal the joint where the radome encircles the baymount with the silicone sealant supplied with the antenna.

Important

Be very careful to seal the joint completely. If water enters the radome, the antenna will not perform as expected, and may cause damage to your entire system.

Install XXL radomes (if applicable)

If your system includes XXL radomes, you can most easily install them on the ground. See [Figure 6](#) on page 12, [Figure 5](#) on page 11, and [Figure 7](#) on page 13.

Radome halves are match-marked in pairs (A-A, B-B, etc.). In order to align the flange bolt holes, be sure to pair them according to their match-markings.

NOTE

Radome match-markings bear no relation to radiator and feedline markings. Install any radome on any bay.

Antenna Installation

- a. Unpack the radomes:
 - (1) Each radome is shipped partially assembled on its own pallet. Disassemble the radome halves and the radome mounts.
 - (2) Identify the top radome half (1) by its wide mating flange and the bottom radome half (2) by its narrow mating flange and drain holes.
 - (3) Separate the radome halves, keeping the 1/4" radome flange hardware (3) for installation.
 - (4) Remove the closure plate hardware (4) at the edges where the mount will slip under the closure plates. Loosen the other closure plate hardware (5) and leave the top closure plate (6) and bottom closure plate (7) in place on the radomes.

- b. Install the radome backplate:

NOTE

With XXL radomes, antenna azimuth is controlled by the design of the tower mounts. No further alignment by the installer is necessary.

- (1) Locate the radome backplate (8) on the feedline (9) as shown, exactly opposite the baymount flange (10).

NOTE

Use shims or washers (11) as necessary to fit the back support mount to the mount flanges.

- (2) Bolt the radome backplate to the feedline mount flange, using the 3/8" backplate hardware (12).

- c. Install the bay radiator:

- (1) Install a lightly lubricated O-ring (13) into the O-ring groove in the baymount flange.
- (2) Install the radiator (14) onto the baymount flange, making sure the O-ring remains within the groove and is not pinched between the flange surfaces.
- (3) Secure the radiator using the baymount hardware (15).

- d. Install the radome:

- (1) Place the top radome half (1) over the radiator (14) and feedline (9) and into the backplate (8), slipping the ends of the radome backplate under the top closure plate (6).
- (2) Place the bottom radome half (2) over the radiator and feedline and into the backplate and top radome half, inserting the end of the radome backplate under the bottom closure plate (7).
- (3) Bolt the radome halves loosely to the backplate with the radome-backplate hardware (16).

NOTE

You may have to squeeze the radome flanges together slightly with a clamp to start the nuts. Get all these nuts and bolts in place before tightening them.

- (4) Fasten the two radome halves together with the 1/4" radome flange hardware (3), starting at the feedline side and working around both sides to the outer edge. Tighten the radome flange hardware.

Antenna Installation

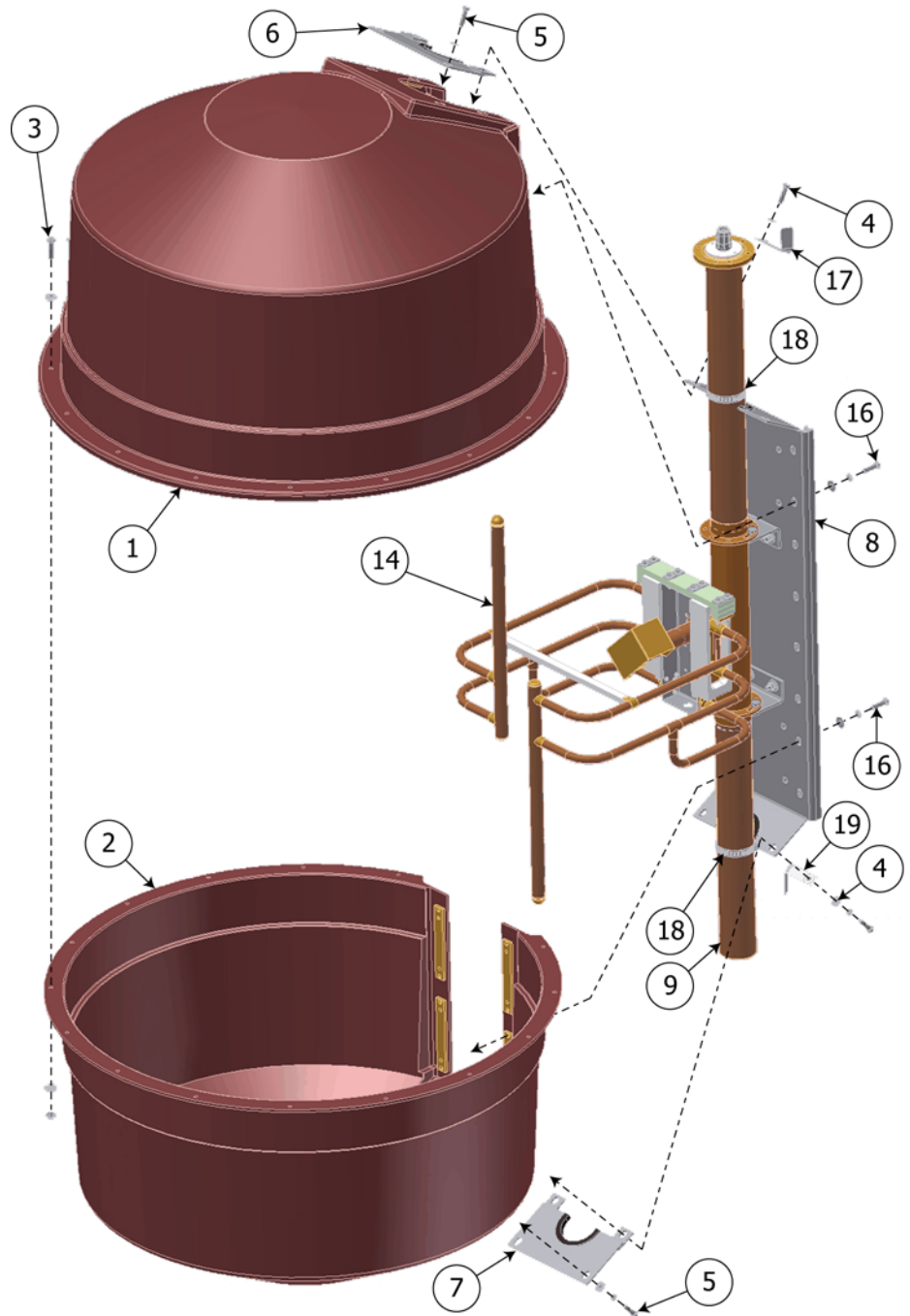

1	Top radome half	8	Backplate
2	Bottom radome half	9	Feedline
3	Radome flange hardware	14	Bay radiator
4	Closure plate hardware	16	Radome-backplate hardware
5	Closure plate hardware	17	Top ground strap
6	Top closure plate	18	Band clamp (2)
7	Bottom closure plate	19	Bottom ground strap

Figure 5. XXL radome installation
(radome, closure plates and ground straps)

Antenna Installation

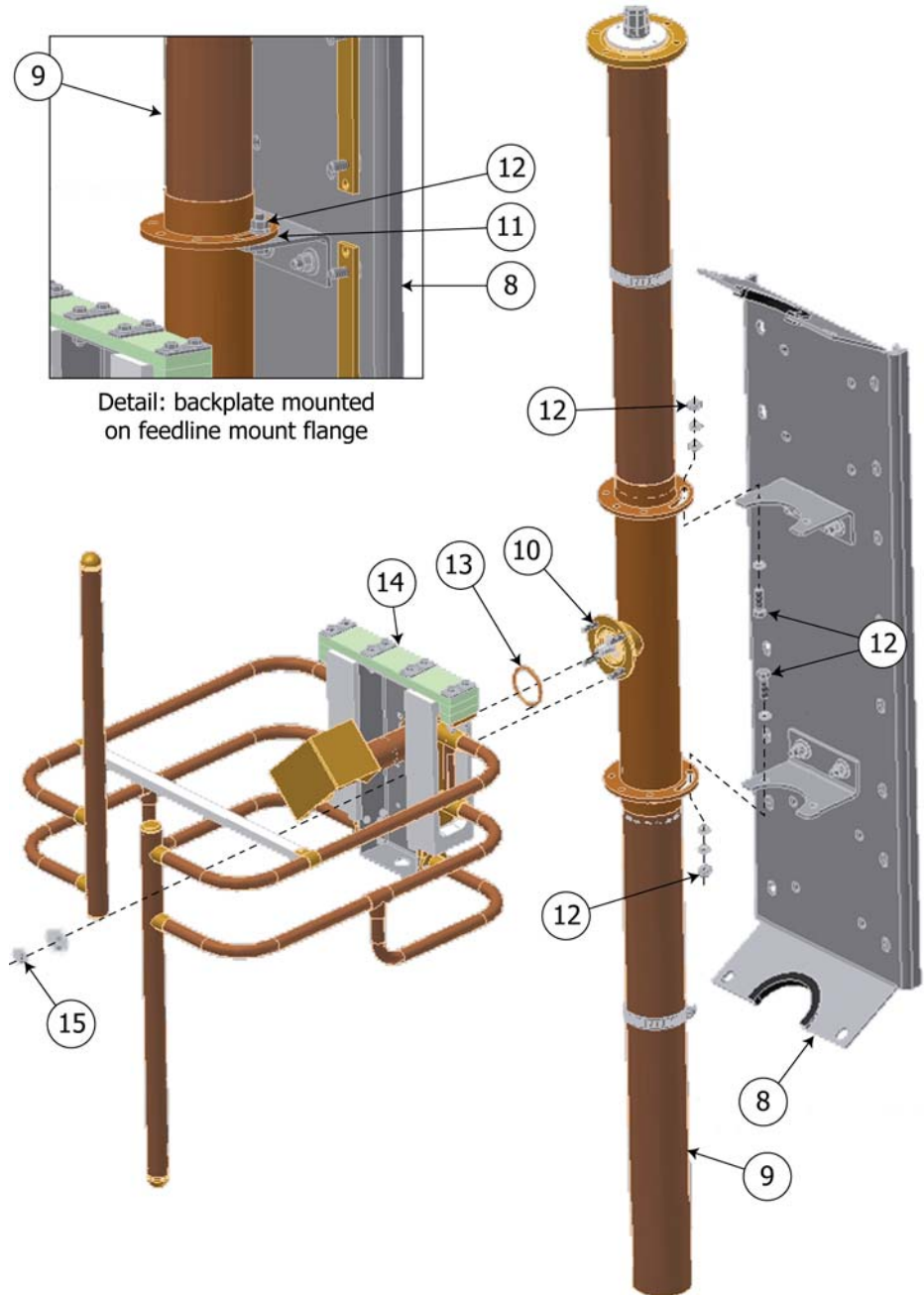

8	Radome backplate	12	Backplate hardware
9	Feedline	13	O-ring
10	Baymount flange	14	Bay radiator
11	Shims or washers as needed	15	Baymount hardware

Figure 6. XXL radome installation (backplate and bay radiator)

e. Install the closure plates and ground straps:

- (1) Install the top closure plate hardware (4) through the the top ground strap (17), closure plate (6), and into the threaded hole in the top of the radome (1).

Antenna Installation

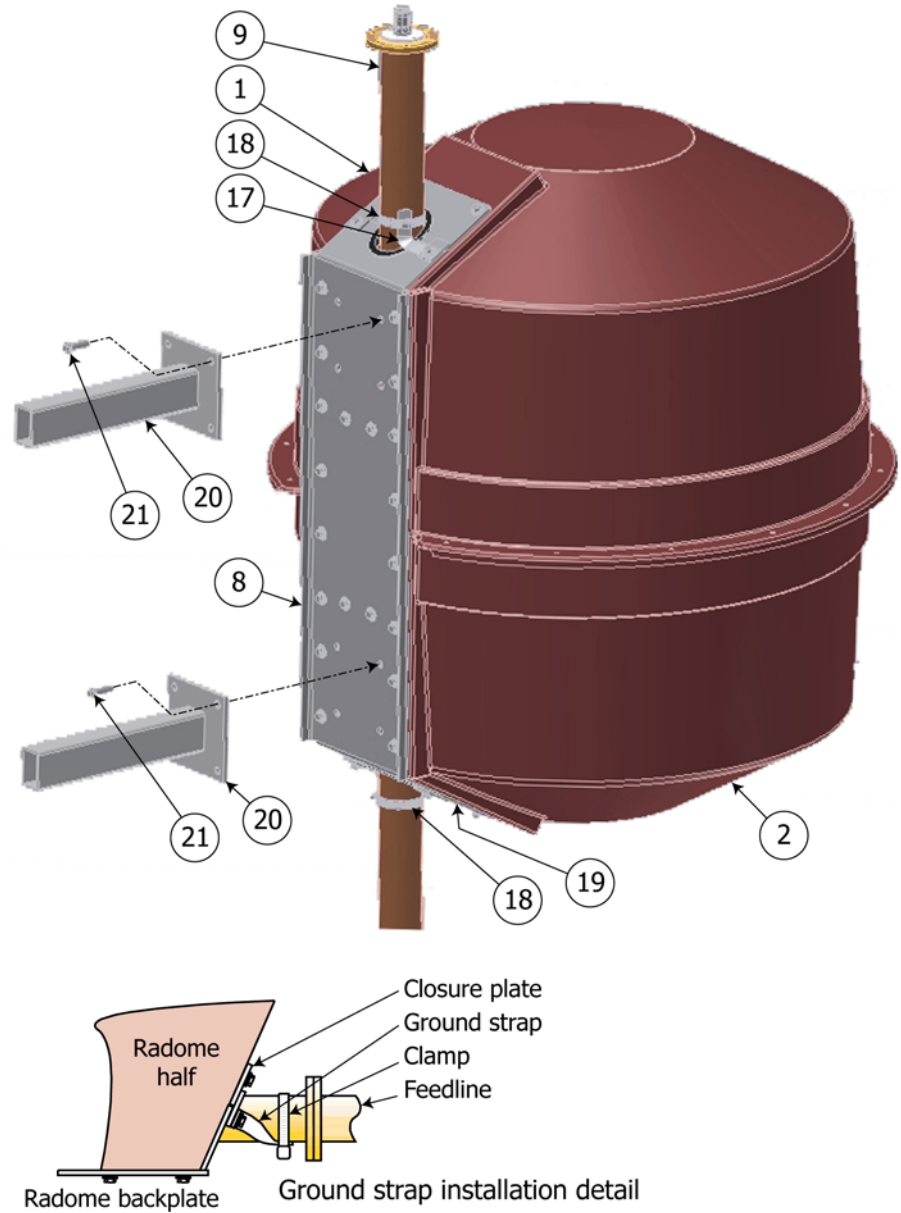

1	Top radome half	18	Band clamp (2)
2	Bottom radome half	19	Bottom ground strap
8	Backplate	20	Tower mounts (2)
9	Feedline	21	Box bolts or 1/2" hardware (8)
17	Top ground strap		

Figure 7. XXL radome installation (tower mounts)

- (2) Secure the ground strap to the feedline (9) - see detail in [Figure 7](#) - using the band clamp (18).
 - (3) Repeat for the bottom closure plate (7) and the bottom ground strap (19).
- f. Tighten the closure plate hardware (4) and (5) and the radome-backplate hardware (16).

Important

Be very careful to seal the radome completely. If water enters the radome, the antenna will not perform as expected, and may cause damage to your entire system.

- g. Seal the closure plates and the joints where the radome meets the backplate with the silicone sealant supplied with the antenna.
- h. Install the tower mounts (20) onto the backplate, using the box bolts (21). Manufacturer instructions for the box bolts are included.

Installing the feedline assemblies on the tower

Feedline mounts vary from installation to installation, to accommodate various tower and mounting pole requirements. [Figure 8](#) shows several common configurations. Your feedline mounts may be one of the common designs shown; if they are not, they will be shown in detail on your installation drawing.

Before you begin installation, study the mounts, the mounting tower leg(s) or pole, and your installation drawing carefully, to determine which mount(s) will be used for each component.

Important!

Remove the tower paint to ensure good electrical contact between the mounts and the tower. If you don't get good contact, the antenna may not perform as designed, and may produce stray signals that will interfere with other services on the tower.

a. Prepare the tower for mounts:

- (1) On the tower, starting at the top, use a steel measuring tape to find the location of each bay in accordance with the installation drawing. Mark the mount locations.
- (2) Mark the specified location of any accessory mounts, such as for the transformer or special coax input line sections, to make sure they will fit as planned.
- (3) Watch carefully for any interferences by tower members or guy wires which were not accounted for in the design.
- (4) Where the mounts will be in contact with the tower leg(s) or mounting pole, scrape the tower paint away to ensure good electrical contact.

b. Install the feedline sections:

CAUTION

Feedline flanges are match-marked. Assemble components in accordance with their match-markings (see [Figure 9](#)) and the installation drawing. If you don't, the antenna will not perform as expected.

CAUTION

Secure each feedline section to its mount before installing the next section, tightening in accordance with [Figure 3](#) and [Table 1](#).

- (1) Starting at the top of the antenna array, install the feedline and feedline mounts carefully, in accordance with your installation drawing and the illustrations in this chapter.

Important!

To avoid damage to the antenna, always lift, position, and attach each section individually. Never try to transport connected feedline sections! Feedline is not designed to support multiple sections and damage will occur.

Antenna Installation

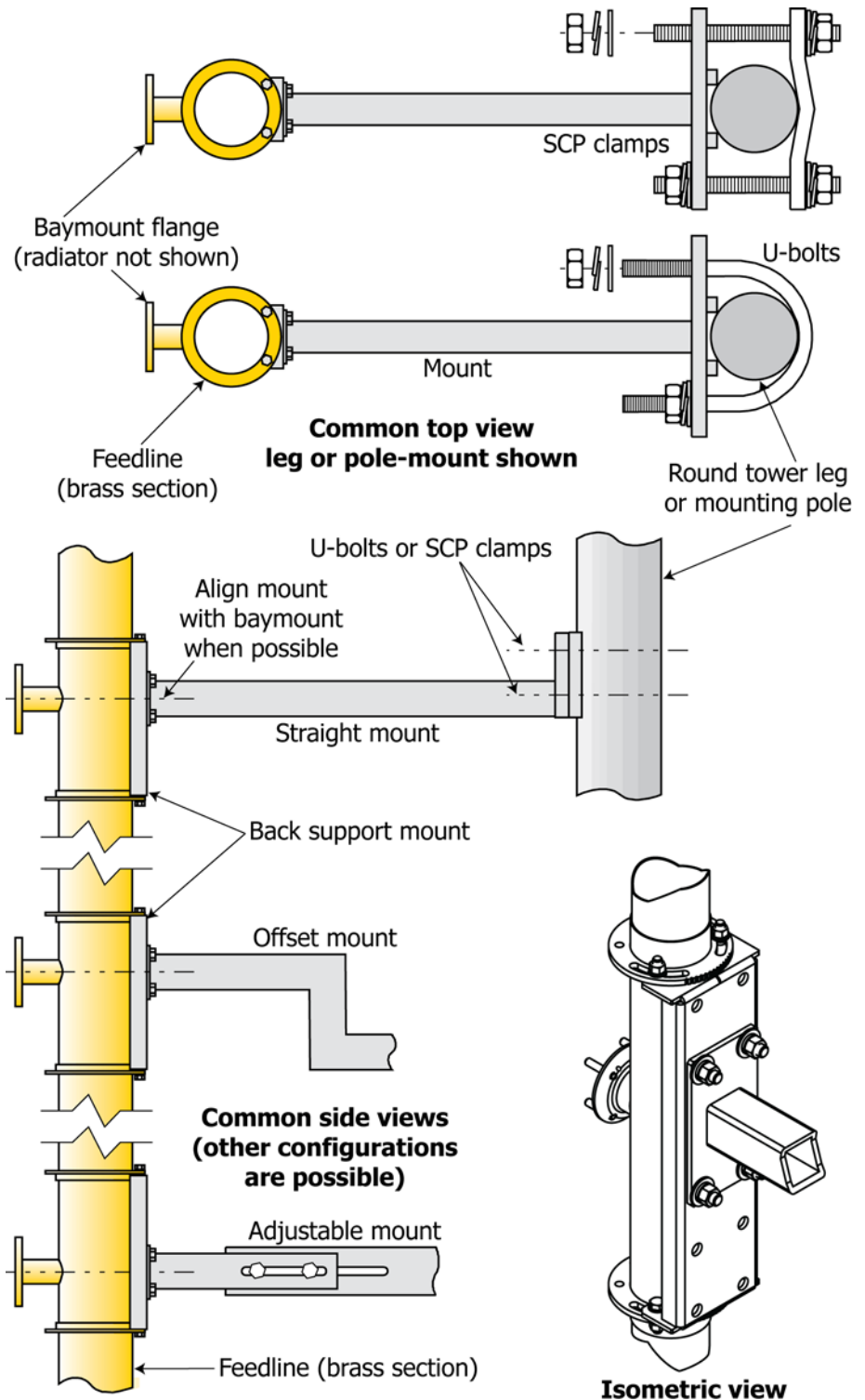

Mounts may vary from bay to bay, especially on tapered towers or where tower obstructions exist. See your installation drawing for your mount configuration and special requirements, if any.

Figure 8. Common feedline mount configurations

Antenna Installation

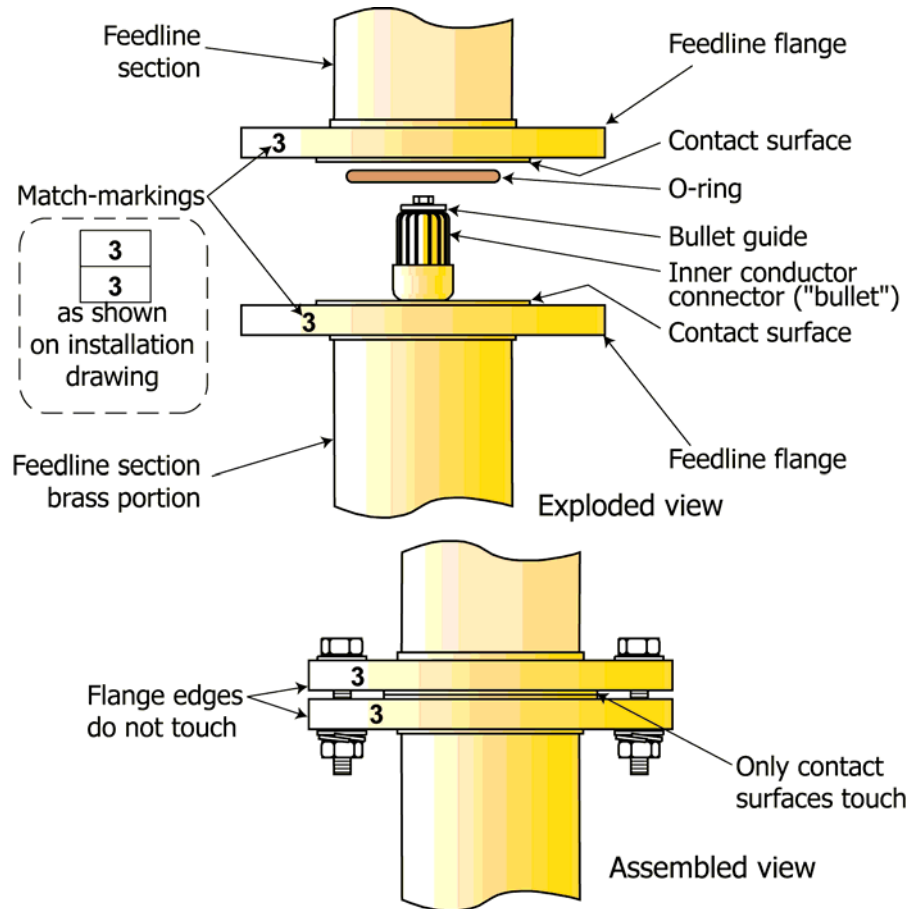

Figure 9. Feedline flange detail

CAUTION

The feedline inner conductors include "bullet guides" (see [Figure 9](#)) to help prevent split bullets. Be sure the bullet guides are in place before assembly.

CAUTION

Do not overtighten the feedline flange hardware (see [Table 1](#) on page 7). Only the contact surfaces should touch, as shown in [Figure 9](#).

- (2) As each feedline section is lifted into place, remove the plastic bags and protective covers from the flanges and install an O-ring, lubricating it with a light coat of petroleum jelly (provided with the antenna).

NOTE

In most cases, the mounts are reversible to clear tower cross-members and other obstructions.

- (3) Align the mounts to the tower leg(s) or mounting pole, then secure them to the back support mount using box bolts.
- (4) Last, secure the mounts to the tower in accordance with your installation drawing (commonly using U-bolts).
- (5) When all mounts are in place, sight along them vertically and align them before finally tightening the hardware.

c. Touch up any exposed metal on the tower or pole.

If any problems appear during this process, please call Shively Labs and discuss them with the installation designer.

Installing the transformer

One of the unique features of Shively Labs antenna systems is the adjustable impedance-matching transformer provided with the antenna. It allows the installer to compensate for changes in the input impedance caused by the installation (tower, conduit, ladder, etc.).

NOTE

The transformer may be oriented in whichever direction you wish (see [Figure 10](#)). Make it easy for yourself to reach for adjustment at startup.

Install the transformer between your transmission line and the feedline. The male end (with the inner conductor connector in place) always goes at the top. Transformer mounts are generally similar to feedline mounts and should be installed in the same manner.

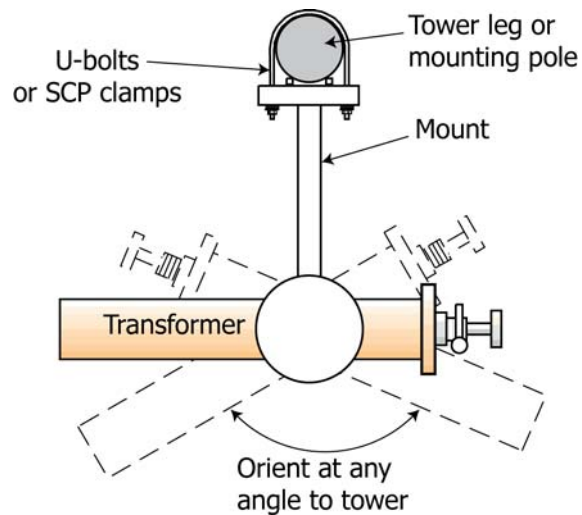

Figure 10. Transformer Installation, top view

Installing parasitic elements (if applicable)

If your antenna includes parasitic elements, these are shown on your installation drawing. Install them exactly as shown on the installation drawing.

CAUTION

Be sure to follow all dimensions and angles shown on the installation drawing, or your antenna will not perform as expected.

Each parasitic element clamps directly onto the feedline with clamps.

On the mounting bracket for each horizontal parasitic element, there is a small spot of weld which you must line up with the centerline of the radiator. This alignment is critical to the proper directionality of the antenna.

3

De-Icer Installation (if applicable)

De-icer description

WARNING

Installation should be performed only by personnel experienced in RF systems, qualified in electrical work, and familiar with this equipment.

The de-icer system consists of the heating elements in the bays, their branch cables, and the main harness. The main harness consists of a bay junction box for each antenna bay, interbay cables, and a "pigtail" of wires about 10 feet (3 meters) long which you will connect to the tower junction box you are to provide.

The de-icer system requires 220 VAC, 50 - 60 Hz., single-phase. [Table 2](#) shows approximate heater leg resistances and current draw, respectively.

Your system may also include specially-ordered items, such as a ground-mounted control box, a power cable extending up the tower, or a tower-mounted thermostat.

The following will help in installation:

- Electrical schematic, overall: [Figure 11](#) on page 21.
- De-icer control box layout: [Figure 13](#) on page 23.
- De-icer electrical specifications: [Table 2](#) on page 24.
- Thermostat readings: [Table 3](#) on page 24 and [Table 4](#) on page 24.

CAUTION

Remember that conditions may be favorable for icing on the tower, even if they are not on the ground.

Shively Labs deicers are designed to prevent ice from forming on antenna elements and are not designed to melt ice that has already formed. For this reason, Shively Labs recommends that the system be installed with a tower-mounted dual-setting thermostat assembly (Shively Labs Model 55522-G502) and de-icer control box (Shively Labs Model 94068) that ensure the deicers are operated in the temperature range ice is most likely to form.

Before beginning de-icer installation

Remember!

It is YOUR responsibility to ensure that your installation meets all applicable electrical codes.

We recommend that the installation be reviewed by a qualified electrician before you apply power.

CAUTION

De-icer heating elements are installed in bays as pairs of series-connected heaters. Each individual heater is designed to operate at 120V. Under no circumstances should 240V be applied across one heater, between either hot wire to neutral.

CAUTION

All parts of the de-icer system within about 20 feet (6 meters) of any radiator must be shielded from RF energy, and the entire outdoor portion of the system must be made waterproof.

CAUTION

Note that unless an exterior box has been ordered specially, a de-icer control box purchased from Shively Labs is designed for interior installation only.

De-Icer Installation (if applicable)

CAUTION

To prevent electrical short-circuiting, secure all cables to minimize wind-induced motion and chafing against edges of system or tower components.

CAUTION

It is important that you ground *both* the tower junction box and the control box, as shown in [Figure 11](#) on page 21.

CAUTION

When testing the thermostat in step k, be sure to disconnect one or both thermostat leads before taking resistance readings. Otherwise, readings may be affected by other components.

CAUTION

The resistance readings in tables 3 through 6 are for the Shively-supplied portion of the systems only, and do not take into account any long run of cable to the tower and up to the antenna.

CAUTION

An improperly installed de-icer can overheat and damage your antenna.

Installation procedure

De-icer installation

- a. Install the main de-icer harness with its bay junction boxes as shown in the installation drawing and [Figure 11](#) on page 21.
- b. Connect the leads from each bay de-icer to the main harness in that bay's junction box as shown in [Figure 12](#) on page 22. Secure any slack in these cables to the feedline with tie-wraps to avoid wind damage.
- c. Furnish a tower junction box as shown schematically in [Figure 11](#) to connect the antenna's de-icer harness to the main power.

NOTE

Shively recommends the use of shielded braided polyethylene-covered wire or rubber-sheathed flexible metal conduit or rigid conduit and weather-tight fittings at all junctions.

- d. Using tie-wraps, secure the entire length of the de-icer harness to the RF feedline at about 24" (60 cm) intervals. Run the ten-foot pigtail along a feedline mount to the tower junction box and secure it to the mount and the tower.
- e. Furnish a main control box as shown schematically in [Figure 13](#) on page 23.

NOTE

The wire size must account for the total current draw of the cable run to the antenna and the de-icer system itself.

- f. Run a power cable from the control box in the building to the tower junction box and connect it to the de-icer harness pigtail(s) in the tower junction box.

De-Icer Installation (if applicable)

NOTE
Customer-supplied items are shown in broken lines.

NOTE
A liquid-tight conduit connector (3/8" conduit size by 1/2" hub size) for the harness entry to the tower junction box, is packed loose with the de-icer harness.

NOTE
Shively recommends the use of shielded or braided polyethylene-covered wire or rubber-sheathed flexible metal conduit and weather-tight fittings at all junctions.

CAUTION
Shively Labs's de-icer control box, Model 94068, is designed for interior installation only.

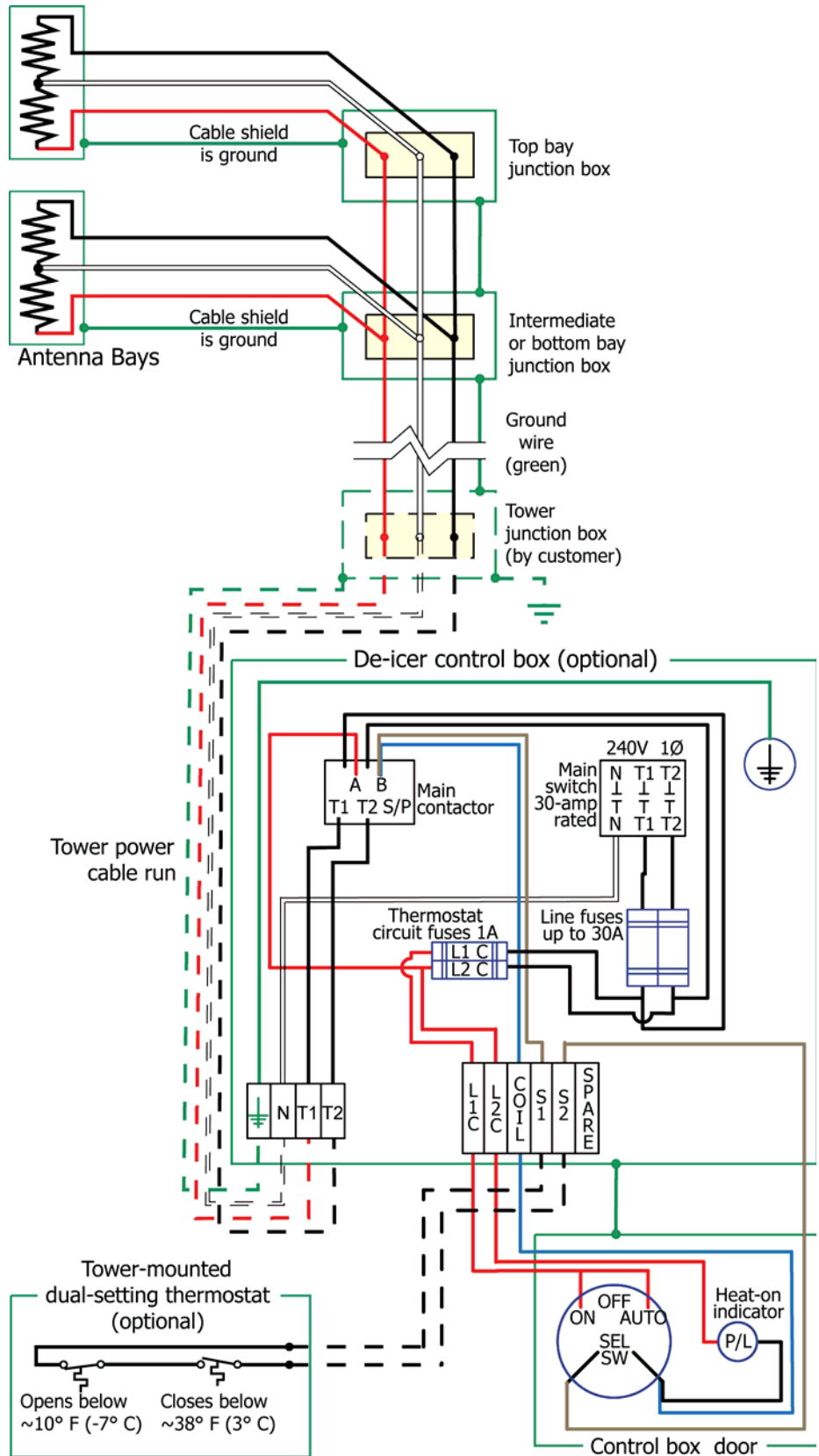

Figure 11. De-icer system schematic diagram, overall

De-Icer Installation (if applicable)

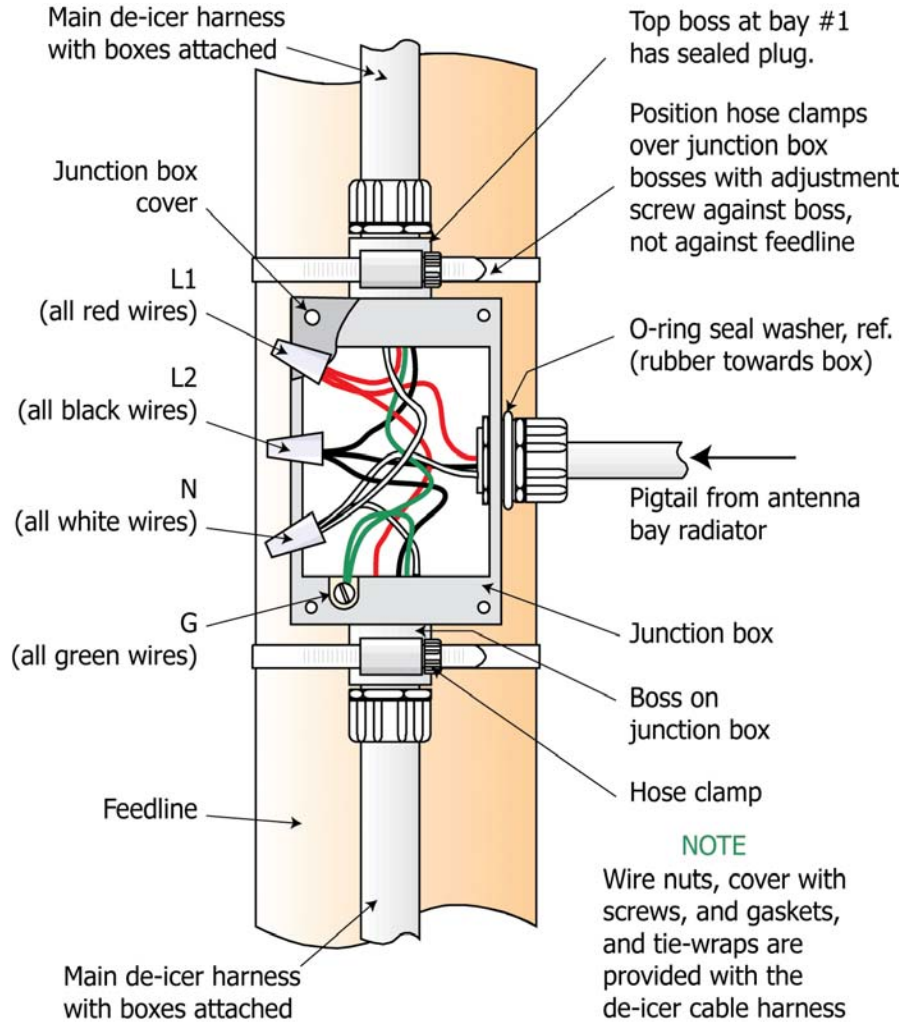

Figure 12. Bay junction box installation

g. Take initial readings:

- (1) After installation is complete, measure the resistance from each heater leg to ground to ensure that there are no short-circuits. Resistance should be infinite.
- (2) Turn the de-icer on by switching it to Manual, and measure its current draw with an ammeter. Compare this reading with [Table 2](#) on page 24.
- (3) Record the resistance and current readings in your maintenance log for future reference in troubleshooting the de-icer system. See [Sample maintenance log](#) on page 37 for a suggested log format.

De-Icer Installation (if applicable)

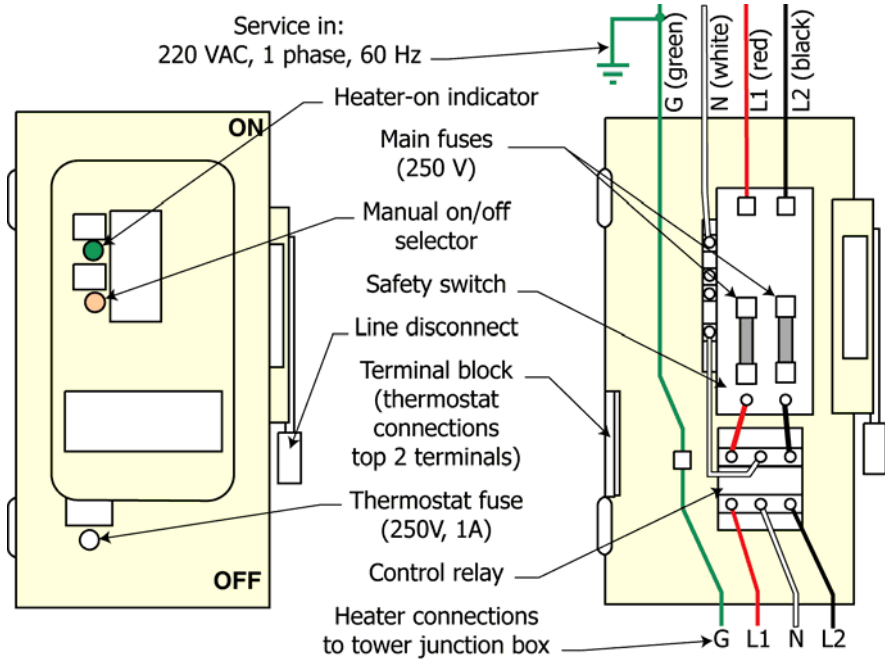

Figure 13. Shively de-icer control box layout

Thermostat installation (if applicable)

You may locate the thermostat, if applicable, at your discretion. We recommend mounting it as close as practical to the antenna.

- a. Mount the thermostat and connect the thermostat leads to points S1 and S2 in the control box as shown in the schematic diagram, [Figure 11](#) on page 21.
- b. Before you connect the thermostat, take initial readings:

CAUTION

When taking thermostat resistance readings, be sure to have one or both thermostat leads disconnected. Otherwise, readings may be affected by other components.

- (1) Measure the resistance across the thermostat circuit and from it to ground to ensure that there are no short-circuits. Test at the location shown in [Figure 11](#).
 - (2) Measure the resistance across each heater leg. Be sure to add in the resistance of any long cable runs from the control box to the antenna.
 - (3) Thermostat readings should be as shown in [Table 3](#) on page 24 (single thermostat) or [Table 4](#) on page 24 (tandem thermostat).
 - (4) Record the resistance and current readings in your maintenance log for future reference in troubleshooting the de-icer system.
- c. Complete thermostat electrical connections.

De-Icer Installation (if applicable)

Table 2. De-icer specifications

NOTE Measurements are between neutral and either "hot" wire. Resistance hot-to-hot will be double the value quoted here	High-Band (98.0-108.0 MHz)		Low-Band (88.0-97.9 MHz)	
	Heater Leg Resistance, Ω	Heater Leg (T1 or T2) Current Draw, amps	Heater Leg Resistance, Ω	Heater Leg (T1 or T2) Current Draw, amps
1-Bay, single circuit	53	2.1	47	2.3
2-Bay	27	4.1	24	4.6
3-Bay	18	6.2	16	7.0
4-Bay	13	8.3	12	9.3
5-Bay	11	10.4	9	11.6
6-Bay	9	12.4	8	13.9
7-Bay	8	14.5	7	16.2
8-Bay	7	16.6	6	18.6
10-Bay, each of 2 circuits	12	10.4	8	11.6
12-Bay, each of 2 circuits	8	12.4	6	13.9
14-Bay, each of 2 circuits	8	14.5	8	16.2
16-Bay, each of 2 circuits	8	16.6	4	18.6

Table 3. Single thermostat readings

Reading Location	Ambient Temperature	Resistance = 0 ohms (short circuit)	Resistance = infinite ohms (open circuit)
Leg-to-Ground	Any	Defective thermostat or shorted leads	OK
Leg-to-Leg	Above about 38° F (3.3° C)	Defective thermostat or shorted leads	OK
	Below about 38° F (3.3° C)	OK	Defective thermostat or broken leads

Table 4. Tandem thermostat readings

Reading Location	Ambient Temperature	Resistance = 0 ohms (short circuit)	Resistance = infinite ohms (open circuit)
Leg-to-Ground	Any	Defective thermostat or shorted leads	OK

De-Icer Installation (if applicable)

Table 4. Tandem thermostat readings (continued)

Reading Location	Ambient Temperature	Resistance = 0 ohms (short circuit)	Resistance = infinite ohms (open circuit)
Leg-to-Leg	Above about 38° F (3.3° C)	Defective thermostat or shorted leads	OK
	Between about 10° and about 38° F (-6.7° to 3.3° C)	OK	Defective thermostat or broken leads
	Below about 10° F (-6.7° C)	Defective thermostat or shorted leads	OK

Precautions

Important

Shively Labs will not accept responsibility for antenna failure due to operation without proper purging or positive pressure of dry air or dry nitrogen.

Pressurization

After the antenna is installed and all lines are connected, it is necessary to check the system for leaks, purge with dry gas (cylinder dry nitrogen or air from a compressor-dehydrator) to remove all moisture, and leave the system pressurized with dry gas to avoid future infiltration of moisture. These steps must be taken before RF power is applied to the system.

CAUTION

When pressurizing the system, never use a "garage" air compressor, as it will not clean the air and will blow both moisture and contaminants such as oil and graphite into the coaxial system.

Step 1. Test for leaks

- a. Connect a source of dry gas (cylinder nitrogen or air from a compressor-dehydrator) to the system as shown in [Figure 14](#) on page 28.

CAUTION

Be sure to use a good quality pressure gauge which will read accurately in the 5 - 20 psig (35 - 135 kPa) range; don't depend on the cylinder gauge, which will not be accurate at a low pressure.

Pressure Correction:

$$P_C = \frac{(P_R + 14.7)(T_1 + 460)}{(T_2 + 460) - 14.7}$$

where P_C = corrected final pressure, psig

P_R = final pressure as read, psig

T_1 = beginning temperature, degrees F.

T_2 = final temperature, degrees F.

- b. Pressurize the system to seven (7) psig, then close the shutoff valve. Give the system one half hour to stabilize, then record the pressure and the temperature.
- c. Wait twenty-four hours, then read the pressure and the temperature again and use the pressure correction formula at left to obtain a corrected pressure for comparison.
- d. If the system loses pressure at an unacceptably high rate, re-pressurize it, leaving the gas supply on. A rule of thumb is that the final pressure should not be less than half the initial pressure after twenty-four hours.
- e. Find the leak(s), using a leak detector or soap bubbles. (The most common cause of leakage is an O-ring pinched in a flange.)
- f. Correct any leaks that are found. Then repeat the leak test until the results are satisfactory.

Step 2. Purge the system

All pressurized Shively Labs antennas have a pressure relief valve at the top of the feedline (center-fed feedlines have a relief valve at each end). This valve is set to open at about 10 psig. So, to purge the system, it is not necessary to send a worker to the top of the antenna to open a valve or loosen a flange. Simply raise the internal pressure enough to open the relief valve. When the purge is complete, lower the pressure and the valve will close.

When the system is new, and any time that it has been opened, it must be purged with dry gas before operation to eliminate moisture. The dry gas used may be dry cylinder nitrogen or air from a compressor-dehydrator.

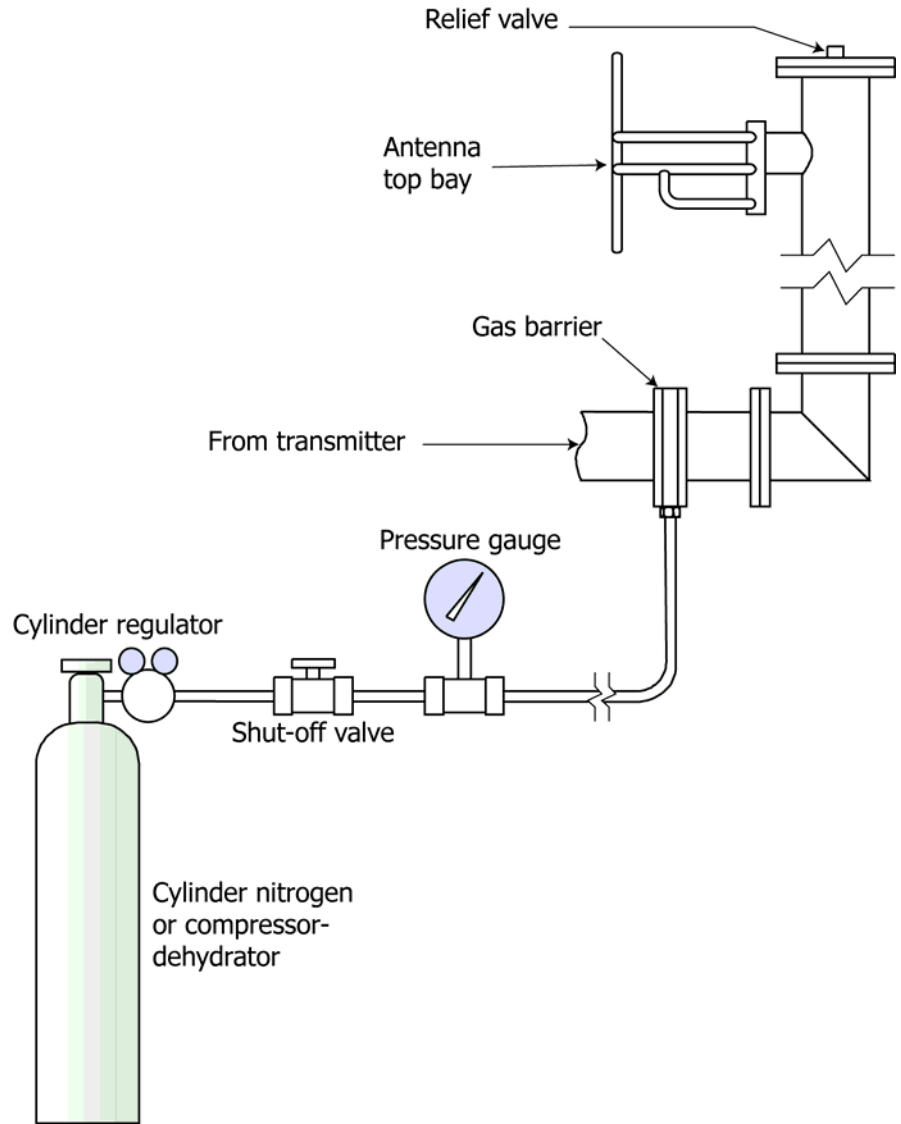

Figure 14. Pressurized gas schematic

CAUTION
 If all moisture is not removed from the interior of the system, it will condense when the weather cools. The resulting water will cause arcing and permanent destruction of the coaxial system, including the transmitter output network.

Purge your system as follows:

- a. If you have any liquid water in your transformer or your transmission line, use a vacuum pump to dry the transmission line and transformer. Apply as much vacuum as you can to the system and hold the vacuum for 8 hours. This should remove any liquid water. [A vacuum pump can be rented or borrowed from a refrigeration contractor.]
- b. Determine how wet the system is and thus how much purging will be required. If a system of rigid line carefully protected from weather and assembled in dry weather is average, a system exposed to moisture during storage or installation will be relatively wet. New semi-flex transmission line, delivered pressurized with dry gas, will be relatively dry; used semi-flex will be extremely wet.

Startup and Operation

- c. Determine the volume of dry gas to use for the purge. [Table 5](#) shows approximate volumes inside various coax sizes. Add the length of the antenna to the length of the transmission line to determine the overall length of the system. You may ignore the volume inside the radiators. We suggest three volume changes of dry gas for an "average" system.

Table 5. Volume of coax per 1000 feet of length

Coax Size	Volume
1-5/8"	13 cu. ft. (0.37 m ³)
3-1/8"	50 cu. ft. (1.4 m ³)
4-1/16"	90 cu. ft. (2.6 m ³)
6-1/8"	200 cu. ft. (5.7 m ³)
9-3/16"	450 cu. ft. (13 m ³)

NOTE

A standard nitrogen cylinder (9 inch diameter by 55 inches tall) contains about 200 cubic feet (5.7 m³) of gas.

CAUTION

Do not raise pressure over 20 psig (~135 kPa), even briefly. Increase pressure slowly, noting that it takes time for the entire system to fill with the new pressure and the pressure gauge to stabilize.

- d. Connect a source of dry gas (cylinder nitrogen or air from a compressor-dehydrator) to the system as shown in [Figure 14](#). Raise the gas pressure to 12 or 13 psig (83 - 90 kPa).

CAUTION

When purging, you must blow dry gas *through* the system, not just maintain a pressure. The gas *volume* accomplishes the purge.

- e. If the relief valve has opened, the nitrogen cylinder will slowly drain or the compressor-dehydrator will not shut down.

Step 3. Leave the system pressurized

After completion of the purge, reduce the supply pressure to about 5 to 7 psig, allowing the pressure relief valve to close and seal the system.

After the pressure has stabilized, keep careful note of cylinder pressure or compressor-dehydrator running time, to be sure that no large leaks have been overlooked. This is especially important immediately after installation or any subsequent opening and reassembly.

Impedance trimming

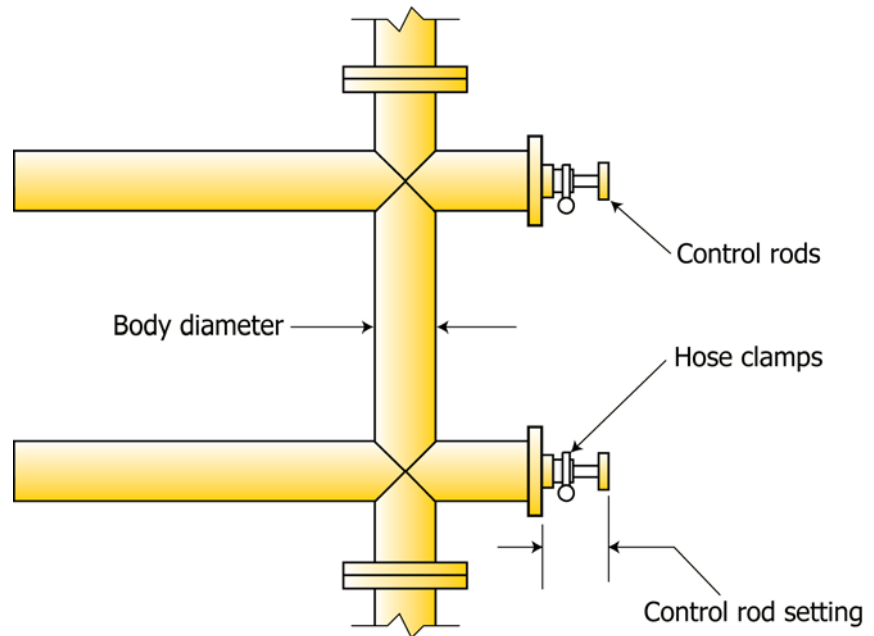

Figure 15. Impedance-matching transformer

The transformer has been factory-adjusted to 50 ohms at your frequency. You will find a scribed line on each control rod shaft. It can be operated at that setting, but it will give optimal performance on your tower if you readjust it after installation.

Adjust the transformer as follows:

- a. Loosen the hose clamps on the control rods enough to allow the rods to move.
- b. Grasp either control rod and slide it in or out about 1/4 inch or 6 millimeters. It will move stiffly because of O-ring friction.
- c. Read the VSWR. If the reading went down, move the control rod again in the same direction. If the VSWR went up, move the same rod in the opposite direction.

Table 6. Factory control rod settings

Nominal Transformer Size	Factory Control Rod Setting (Figure 15 on page 30)
1-5/8"	3-3/4" \pm 1/16" (95 \pm 1.5 mm)
3-1/8"	2-3/4" \pm 1/16" (69 \pm 1.5 mm)
4-1/16"	3-1/2" \pm 1/16" (89 \pm 1.5 mm)

- d. Keep adjusting the same rod until no further improvement is seen. Adjust the second rod in the same manner. If you get "lost," return both rods to the factory setting ([Table 6](#)) and start over.
- e. Return to the first rod, and so forth, until you have the lowest possible VSWR or return power reading. This is the optimal transformer setting.

- f. VSWR at this point should be below 1.10 : 1. If it is not, call Shively Labs to help identify the problem.
- g. When you have set the transformer, use a sharp point to scribe the shaft where it leaves the flange collar.
- h. Record the control settings of the two control rods and file this information with this manual for future reference.
- i. Tighten both hose clamps. If the clamps are left loose, vibration may change the adjustments.

System sweep (recommended)

Shively Labs strongly recommends that you perform a system sweep of your transmission line and antenna while you have the installation crew on site. Should any problems arise later with your antenna, it will be extremely helpful to know what the system's characteristics were when it was new. We recommend you perform a system sweep after installation.

CAUTION

A high voltage standing wave ratio (VSWR) may indicate damaged transmission line or incorrectly assembled components. This condition will cause serious damage to your equipment when full power is applied.

Many riggers can sweep your system after installation or recommend a contractor to perform it. Alternatively, Shively Labs makes available instructions for system sweep on our Web site, www.shively.com.

Checkout

Before beginning checkout of the antenna system, be sure the following items have been done:

- The antenna system has been installed in accordance with this manual and the installation drawing.
- The de-icer system, if purchased, has been checked out in accordance with [Chapter 3](#).
- All radiators are operating; impedance has been trimmed, and VSWR is low.
- The transformer settings and initial characterization data have been recorded.
- The system is gas-tight and purged.

Check the system out as follows:

- a. Bring up RF power slowly and observe transmitter readings, stability, and general operation.
- b. Run at about half power for at least an hour, reading forward and reflected power, stability, etc.
- c. If the system is stable and seems to be operating properly, bring it up to full power. Take initial readings, and repeat the readings periodically.
- d. Performance readings should not change, and there should be no evidence of heating in the antenna system.

If any problem is found, fix it now. Call Shively Labs if you need help or advice.

Antenna operation

CAUTION

Don't exceed the rated power capacity of the antenna.

To obtain the best performance and dependability, read and follow the maintenance and troubleshooting recommendations in [Chapter 5](#) of this manual.

De-icer system operation

CAUTION

Don't leave the de-icer on for extended periods when the weather is above 50° F (10° C); doing so may shorten the life of the heater element(s).

There is a generous margin of safety built into the de-icer system, and operation for prolonged periods below 50° F (10° C) will not harm the system. If icing conditions are expected, the heaters should be turned on in advance as a preventive measure. It is much easier to prevent ice formation than to remove a heavy coating.

Shively Labs de-icer control system

If you have the Shively Labs de-icer control box and dual-setting thermostat, you have the choice of manual or automatic operation. There are three switch settings: AUTOMATIC, OFF, and MANUAL.

- When the switch is set to AUTOMATIC, the thermostat turns the heaters on and off according to the temperature.
- When the switch is set to OFF, the thermostat is overridden and the heaters will stay off no matter what the temperature.
- When the switch is set to MANUAL, the thermostat is overridden and the heaters will stay on no matter what the temperature.

Precautions

WARNING

Maintenance should be performed only by personnel experienced in RF systems and familiar with this equipment.

WARNING

Don't expose personnel to the medical hazards of intense radio frequency (RF) radiation. Whenever working on the tower in the area of the antenna, turn off all transmitters and lock them out so that they cannot be turned on accidentally.

Important

When you have had the system open for repair, you must purge it again as described in [Purge the system](#) on page 27. Never begin operating the system under power until you are sure all the moisture has been purged from it. You can do permanent damage to the entire system, including the transmitter.

CAUTION

When removing or replacing radiators on the tower, never let the weight of the radiator hang on the inner conductor without bolting. This will damage the connector and possibly the inner conductor itself. Support the weight of the radiator until the flange bolts are tightened.

CAUTION

All O-rings are made of silicone. Do not lubricate them with silicone grease, as this will soften the O-ring. Use only a light lubricating coat of O-Lube (provided) or petroleum jelly; too much may hamper electrical contact and contaminate the interior of the system.

Be sure the O-ring is properly seated in its groove and not pinched between the flange contact surfaces.

Maintenance log

Shively recommends that you keep a maintenance log; in it record performance parameters such as readings of VSWR and de-icer current draw. Such a log can be invaluable in spotting and identifying problems. [Sample maintenance log](#) on page 37 shows a suggested log form you may use if you like.

Physical inspection

Important

Give your antenna a full inspection at least once per year!

The antenna system should operate for years if properly installed and maintained. Shively Labs recommends that as a minimum, the antenna should be physically inspected *at least once a year*.

In addition, inspect the antenna after severe weather events, and after climbers have been on the tower working on equipment above the antenna.

In addition to checking the general condition of the antenna and coax:

- Replace dented, broken or bent components.
- Inspect radomes for cracks and plugged drain holes.
- Re-tighten all hardware, hose clamps, and U-bolts to installation specifications.
- Inspect hose clamps and U-bolts carefully for signs of wear or fatigue caused by vibration or tower movement.

De-Icer check

Periodically (we suggest at the end of each winter season), check the condition of the de-icer wiring with an ammeter; compare the legs of the system with each other and with initial readings taken at installation. If an ammeter is not available, resistance readings of each leg will suffice.

Paint

The radiators should never be painted (a coating of paint affects VSWR), and they need no surface protection, since they are made of copper and brass. This includes Teflon or other "ice-prevention" coatings.

It is not necessary to paint the feedline, although no harm will result from doing so.

Radiator removal for repair

In some cases, a damaged radiator may be removed and returned to the factory for repair. The system can then be sealed with a pressure cap, and operation of the antenna can resume with proportional power reduction and increased VSWR.

See the Shively Web site, www.shively.com, for part numbers of pressure caps and other components.

Operating with missing bays may not be possible with some transmitters or antennas that have only a few bays, since some transmitters will not operate into loads with high VSWRs. Contact Shively Labs before attempting this process.

Return policy

When returning any material to the factory, be sure to call your sales representative and obtain an returned material authorization (RMA) number first. Use this number in all correspondence. This number helps us to track your returned item. It will expedite repair or replacement and prevent loss of your material.

Troubleshooting

Contact Shively Labs if necessary to help find the cause of your problem. Outside of 8:00 AM to 5:00 PM Eastern Time, call (207) 329-5118.

Internal arcing

The following may cause internal arcing:

- Physical damage to transmission line, feedline, or radiators. Damage may have been caused by ice, lightning, tower work, or many other factors. Damage may cause arcing directly or by allowing water inside the system.
- Missing or misaligned O-ring, if the system has been opened recently.
- Loss of pressurization.

Broad spectrum RF noise

This indicates that some metal components are not in good electrical contact with the tower. First, check your antenna mounts, then other tower components, to be sure that the tower paint has been scraped away and that all mounting hardware is tight.

Any metal part in poor contact with the tower will constitute a non-linear junction and cast a broad-spectrum signal. This includes antennas, transmission line, mounts, ladders, and other electrical components.

High VSWR at startup or during operation

High VSWR (Voltage Standing Wave Ratio) is caused by any factor which changes the impedance match between the transmitter and the antenna system.

The following may cause high VSWR:

- Wrong antenna for the application and frequency. Make sure the antenna is the correct frequency.
- Split bullet in the transmission line or in the baymount (see [Figure 1](#) on page 4). A split bullet is an inner conductor connector misaligned such that one or more of its contact arms is stuck outside the conductor instead of inside. (A missing bullet will cause infinite VSWR.)
- Radiators out of sequence (especially on a center-fed, null-filled, or half-wave-spaced system).
- Damaged feed strap(s) on a radiator. The feed strap is the brass strip that extends back from the end seal. The length, angle, and straightness of the feed strap are critical to the radiator's performance.
- Components of other services that have entered the RF field (later installations or broken components).
- Physical damage to the transmission line, feedline, or radiators. This may be from ice, lightning, tower work, or any other source.
- Paint applied to the radiators, possibly during a recent tower painting.
- Failure of de-icers, causing excessive ice buildup on one or more radiators.
- Domes missing from vertical arms. An overheating de-icer can melt the solder from domes, spacers, and bushings at the ends of the vertical arms.

Erratic VSWR during impedance trimming

If VSWR readings during transformer adjustment as described in [Impedance trimming](#) on page 30 do not respond reasonably consistently to transformer adjustments, then either there is residual water in the transformer, or the transformer is damaged.

Follow this sequence of actions:

- a. Repeat the purging process as described in [Purge the system](#) on page 27.
- b. Try again to trim impedance.
- c. If VSWR is still erratic, Your transformer is probably damaged. Contact Shively Labs.

Change in coverage

Changes in broadcast coverage may be caused by the same factors that produce VSWR changes. If coverage seems to have changed, look for VSWR changes and use [High VSWR at startup or during operation](#) on page 35 for troubleshooting.

It is important to recognize, however, that apparent changes in coverage may be due to subjective factors or faults of the receiving equipment. Before doing more than checking the VSWR, be sure that an actual coverage change has occurred.

Pressure loss or excessive gas usage

Failure to hold pressure may be caused by the following:

- O-ring missing or poorly installed in transmission line, feedline, or baymount flange.
- Leaky end seal (see [Figure 1](#) on page 4).
- Loose connecting hardware between line segments or between the baymount and the radiators.
- Mechanical damage to transmission line, transformer, or antenna. Check for leaks using soap solution.

Sample maintenance
log

DATE	DE-ICER CURRENT (or resistance)			VSWR	GAS PRESS	OBSERVATIONS Visual Inspection of Antenna, Obstruction Lighting; Hardware Checked; Tower Repairs Accomplished; etc.
	BLACK (b-neut)	NEUT (red-bl)	RED (r-neut)			

