

## Basics of Balanced Combiners

### Introduction

The FM spectrum is becoming an increasingly crowded and complex environment. In addition to the steady increase in station allocations that began in earnest with Docket 80-90 in the 1980's, each allocation is becoming home to more and more transmitters as stations add auxiliary, booster and digital services. At the same time, the station ownership consolidation that began in the 1990's has made it both desirable and easier to consolidate transmission sites.

Until recently, low equipment and leasing costs generally made it more desirable to operate over separate rather than combined antennas. Facilities combining more than two or three stations were generally limited to the largest metropolitan areas and were almost always limited to 12 stations or less, all analog of course. Manufacturers also generally had the advantage of knowing in advance all the stations that were ever likely to operate on the system, and reconfiguration for new frequencies and power levels was seldom ever required.

Today's reality is quite different. Modern sites must be expandable, with twenty or more stations a realistic design goal. Frequencies and power levels can be expected to change throughout the life of the system. Combined facilities routinely house both primary and auxiliary services, making cold start capability and minimal reconfiguration times a basic requirement. And, into the foreseeable future, sites will need to support a combination of digital and analog services.

Several options exist for combining simple combinations of FM signals, especially if the frequency spread is relatively large. However, for complex combining environments, balanced combiners are used almost exclusively. As sites become increasingly complex and crowded, balanced combiners are evolving to become increasingly complex as well, and today's combiners are quite different from systems designed even five years ago.

### Combiner Basics

When more than one signal is broadcast over a single antenna, the signals must be combined in such a way that no chance exists for the signals to feed back into each other's transmitter. Failure to do so would allow spurious intermodulation products (spurs) to be generated within the final amplifier stages of the transmitter, which would then be broadcast over the antenna. Spurs created between FM stations can occur not only in the FM band, but also in the low band VHF and aviation bands. In addition, FCC Rule 73.317(d) specifies that spurs more than 600 kHz removed from the carrier must be attenuated below the carrier frequency by 80 dB or by  $43 + 10\log_{10}(\text{power in watts})$  dB, whichever is less. In practice, stations operating transmitter output powers of 5 kW or greater must usually meet the 80 dB requirement, while stations running lower TPOs fall under the computational method.

Experience has shown that to prevent spurs, each transmitter must be isolated from all others in the system by a minimum of 40 dB, with 46 to 50 dB ensuring regulatory compliance. Spur attenuation is accomplished by a combination of transmitter turn-around loss and filtering. Turn-around losses are inherent to the way spurs are created in the transmitter. These losses typically run in the 6-13 dB range for tube type transmitters, while 15-25 dB is typical for solid state units. An off-frequency signal is attenuated 40 dB as it passes through the bandpass filters of the combiner module toward the transmitter with the spur it creates exiting the transmitter an additional 6-25 dB below the level the signal entered. This spur is then attenuated 40 dB as it passes back through the bandpass filters. The result is spur attenuation of at least 80 dB, with 100 dB or more possible.

Transmitting signals on the same frequency, as occurs in combined digital and analog systems, has its own set of problems. Transmitters broadcasting on the same frequency must be isolated not only from other transmitters in the system, but also from each other. Bandpass filters will not attenuate on-frequency signals and isolation is provided primarily by the directivity of the modern hybrid. Technically, the digital portions of a hybrid HD Radio™ signal are not on the same frequency as the analog. However, because of the very close spacing and the fact that the digital signals bracket the analog, they are beyond the isolation capability of conventional filters and for the sake of combiner design are considered to be the same frequency.

### Document No. [tb-balcombiner\\_basics \(0603\)](#)

A Division of Howell Laboratories, Inc., P. O. Box 389, Bridgton, Maine 04009 USA

(207) 647-3327

1-888-SHIVELY

Fax: (207)647-8273

[www.shively.com](http://www.shively.com)

[sales@shively.com](mailto:sales@shively.com)

*An Employee-Owned Company*

*Certified to ISO-9001:2000*

## The Station Module

The two most popular methods of combining FM signals are the branched combiner, also known as a starpoint, and the balanced combiner. In a branched combiner, each station's transmitter feeds through a bandpass filter into a combining tee. The combining tee is designed to appear as a quarter-wave open circuit to other signals feeding into the system, and provides the fundamental isolation between stations. Because the design of the matching tee (or starpoint) becomes more complex as stations are added, the practical limit for combining stations this way is limited to about 4 stations.

The alternative to the branched combiner is the balanced combiner. In a balanced system, each station generally feeds a station module. The heart of the station module is a hybrid ring, supplemented by either band-reject (notch) or band-pass filters. Additional components such as directional couplers, isolators, patch panels, and station loads are added to the module as required. Like branched combiners, balanced combiners built with notch filters and round bandpass filters require carefully phased lengths of coax between the filters to achieve fundamental isolation and impedance matching.

Balanced combiners employing bandpass filters do not require these phase optimized matching sections to achieve fundamental isolation. In a properly designed balanced module using bandpass technology, all the isolation required by a given station is contained within that station's module. This allows stations to be added in any frequency order. It also eliminates the need for retuning when stations are added, removed, or change frequency.

Being able to isolate a station's transmitters from all off-channel power depends on more than just bandpass filter technology. The combiner module components must be balanced and configured to look the same electrically to energy moving in multiple paths across the module. Achieving this electrical balance and symmetry under varying power loads requires attention to very subtle electrical details, tuning and thermal considerations. Indeed, the computer models that these designs rely on have only recently been developed.

## The Traditional Balanced Combiner System

Until a few years ago, virtually all balanced combiner systems of any size were configured in a "standard" or "single-feed" configuration. In a single-feed configuration (Figure 1) the transmitter outputs of all stations travel through the broadband line in one direction and exit through a single wideband port. The broadband line is the combination of output hybrids and interconnecting coax that carries the combined transmitter outputs to the antenna(s) and is so-named because it carries all the signals extant in the system, regardless of frequency. This includes spurs and signals coupled in from other antennas. Broadband lines are completely bi-directional, making each end both a potential input and output.

The single-feed configuration is limited to a single input per station module, though this input can handle analog, digital, or a combined signal. The transmitter feeds for each station travel in the same direction along the broadband line. Therefore, the broadband line components at the wideband output must be large enough to handle the total average and peak power of all the transmitters in the system. This increases the likelihood that 9" components will be required for large systems, even if a splitter will be used to split the signal into dual 6" feeds.

Single-feed combiners are the easiest to tune because a few marginally tuned modules can be isolated in the slots farthest from the antenna where they have the least impact on the balance of the system. In a balanced combiner system, it is possible to tune a module to optimize the performance of the whole system at the expense of the individual station's module. Unlike back- and cross-feed combiners, only one wideband output is used for an antenna feed. This allows a system reject load to be attached to the wideband output farthest from the antenna where it can dissipate

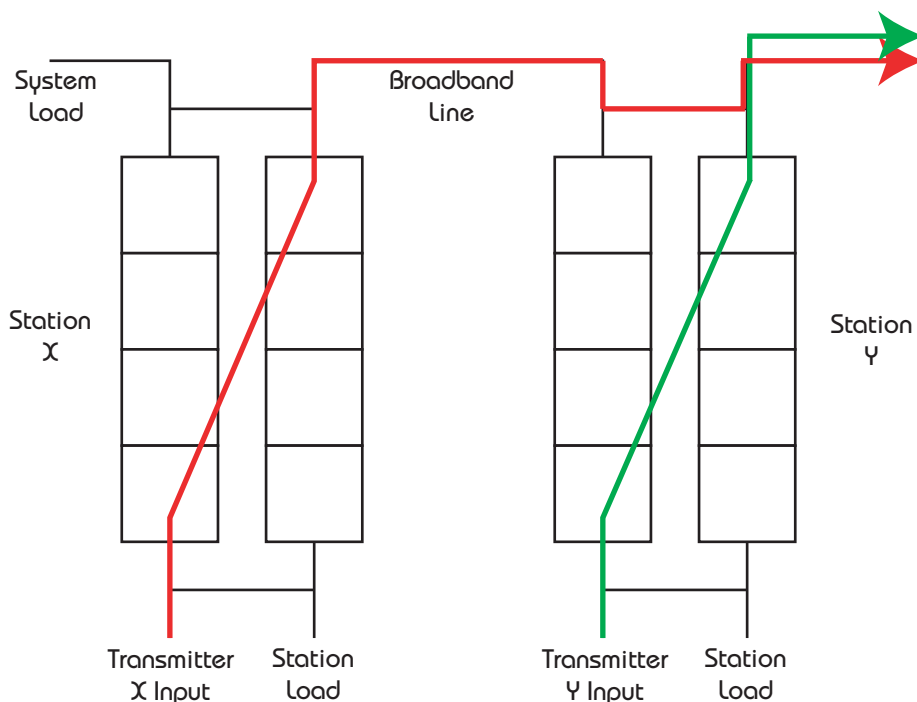

Figure 1. Standard-Feed or Single-Feed Configuration

any energy not attenuated in the bandpass filters of the system. This load also absorbs primary transmitter power not directed to the output leg of the hybrids in each module. When module components are well balanced, this extraneous transmitter power is approximately -35 dB below the combined primary transmitter powers. This is a small amount of power for even the largest combiner chains. However, the amount of extraneous power rises rapidly with even small inefficiencies in the balance of the modules, doubling for every 3 dB decrease in efficiency. The size and operating temperature of the system reject load is not only an indicator of how well balanced the individual modules are tuned, they are also indicators of how difficult it will be to add digital transmitters to the system using back- or cross-feeding because the increased extraneous power will quickly overwhelm the ability of the digital port isolator to deal with it.

Single-feed combiners are sometimes configured so that the transmitter for the last station in the chain is fed into the wideband input port of the broadband line, thus avoiding a full module. This method is used with frequency-agile transmitters to provide an emergency backup for any station in the system with a single transmitter. However, the wideband input port of any combiner chain will have some energy flowing to it - both small amounts of primary transmitter power as well as off-channel energy flowing back from the antenna. Without the system reject load to attenuate this energy, it will feed directly into the transmitter. Therefore, this technique is usually employed at lower power and a supplementary bandpass filter is generally used for fixed frequency applications.

### Back-feed Configuration

The back-feed configuration (Figure 2) was developed as a low-level combining method for analog and digital signals.

When two hybrids are used in a ring configuration (Figure 3) to both split and combine a single input signal, virtually 100% of the signal exits the ring through the hybrid leg opposite the input. Signals can be fed into both input hybrid legs without the signals mixing. In a back-feed system, digital transmitters are fed into the hybrid ports opposite the analog transmitters and a combined digital signal exits the wideband port normally occupied by the system reject load in a single-feed combiner. The combined digital signals can then be broadcast through a separate antenna, or recombined in the antenna radiators using a hybrid. The digital-only transmission line is generally smaller than the analog transmission line. Isolators are used on the digital transmitter inputs to prevent analog on-channel signals from feeding back into the digital transmitter.

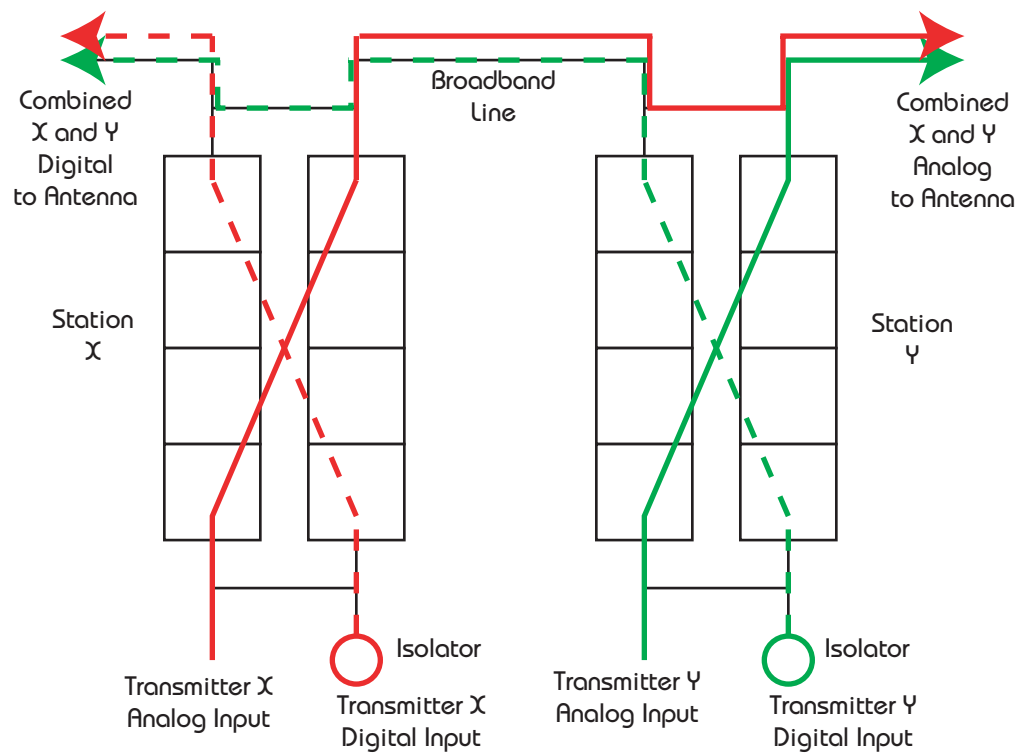

Figure 2. Back-feed Configuration

Isolators are used on the digital transmitter inputs to prevent analog on-channel signals from feeding back into the digital transmitter.

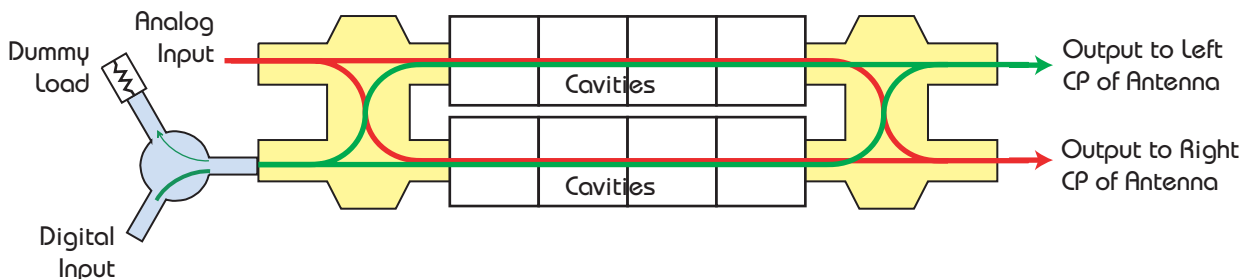

Figure 3. Hybrid Ring

## Cross-feed Configuration

The cross-feed, or split-feed, configuration (Figure 4) is a variation of the back-feed. Rather than segregating digital and analog signals into separate lines, it combines the analog signals of some stations with the digital signals of others. Usually, the analog power is split as evenly as possible, thus minimizing both the average and peak power any broadband line component carries. The advantage to this technique is that 9" components are eliminated in all but the largest systems. Using equal-sized transmission lines also provides redundancy. A failure in a transmission line or portions of the antenna feed system can be overcome by directing a station's primary transmitter (either analog or digital) over the remaining transmission line.

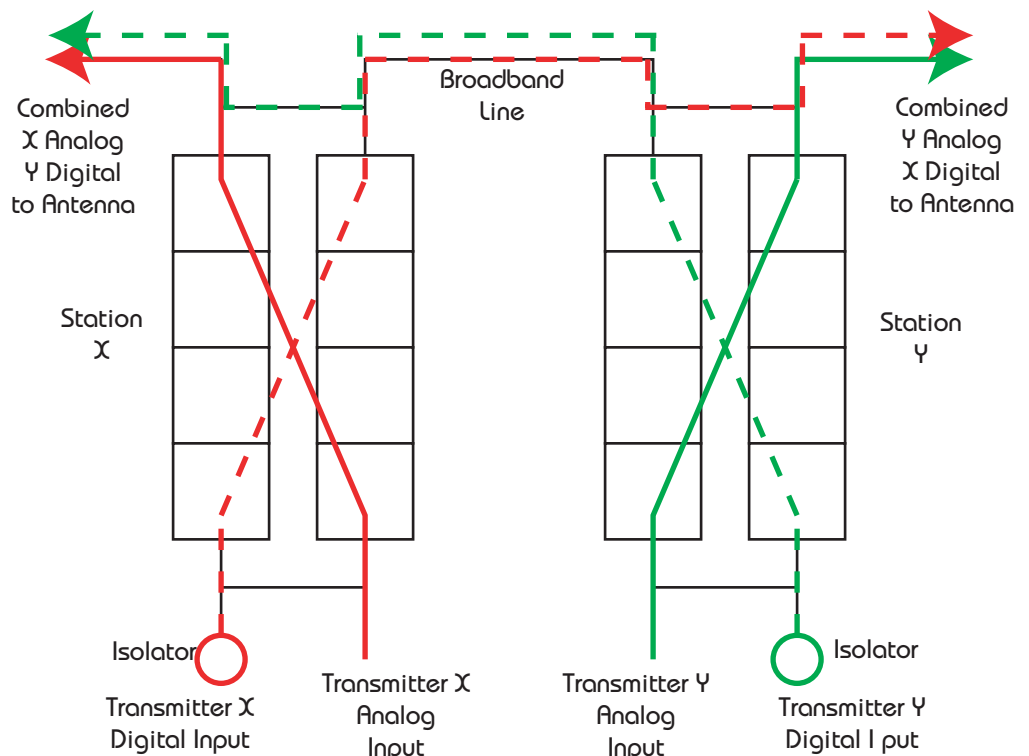

Figure 4. Cross-Feed or Split-Feed Configuration

## Hybrids

The heart of the modern balanced combiner system is the quadrature hybrid. Each station module employs two hybrids, one on the transmitter input(s) of the module and one on the output/broadband portion of the module. These two hybrids operate in three different modes in a balanced module, as illustrated below in Figures 5A, 5B and 5C. In Figure 5A, a signal enters the input leg of a splitter hybrid (Port 1) and is split into two equal signals. Because of the electrical length of the hybrid, the signal exiting Port 4 is 90° degrees out of phase with the signal exiting Port 3. When a hybrid is used as a combiner (Figure 5B) the exact opposite happens and two signals 90° out of phase are recombined into a single signal. When two hybrids are used simultaneously as splitter and combiner, the system is called a hybrid ring.

Each hybrid in a complex balanced combiner system operates in all three modes simultaneously. In older combiners configured for a standard feed, the amount of mixed-mode operation is minimal because the majority of the energy is moving in one direction from a single transmitter input, through the combiner module, and down the broadband line to the antenna. While some reflected energy from the antenna and extraneous energy from the transmitters moves in the other direction on the broadband line, only a small amount of reflected on-channel energy passes back through the system into the transmitter, causing the output hybrid to operate in splitter mode and the input hybrid to operate in

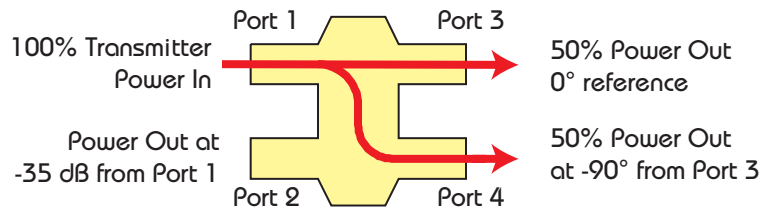

Fig. 5A Hybrid Used as a Signal Splitter

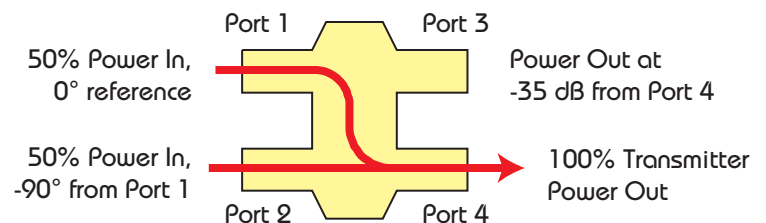

Fig. 5B Hybrid Used as a Signal Combiner

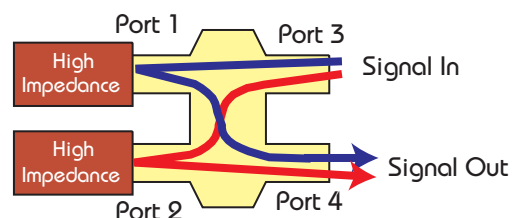

Fig. 5C Hybrid Used as a Signal Reflector

combiner mode.

When combiners are configured for cross- and back-feed operation, on-channel power is coupled from one transmission path into the other via the antenna elements and feeds back into the module through the opposite leg from which it exited. If two transmitters are operating into a single module, power will be exiting and returning through both legs simultaneously. While an efficiently operating antenna will minimize the energy coupled between paths, there will still be sufficient energy returned to require a dummy load for the port opposite the analog transmitter input. If a port is not occupied by a transmitter - for example, if a station runs an analog-only or high-level combined analog/digital signal, a stand-alone dummy load is used on this port. When the port is occupied by a digital transmitter, the dummy load becomes part of the isolator assembly. In cross- and back-feed operation, the signal reflector mode of operation of the broadband hybrid is also much more complex, as both primary transmission power and reflected power travels in both directions along the broadband line.

With power moving in so many different directions at once across these hybrids, it is imperative that they have good VSWR characteristics, and are as balanced and symmetrical as possible. Balanced and symmetrical hybrids show the same VSWR characteristics through each port, even as the hybrid increases in temperature. The more identical the electrical paths through these ports are, the greater the isolation that can be achieved. Figure 6 shows the performance curve of a well balanced and symmetrical hybrid.

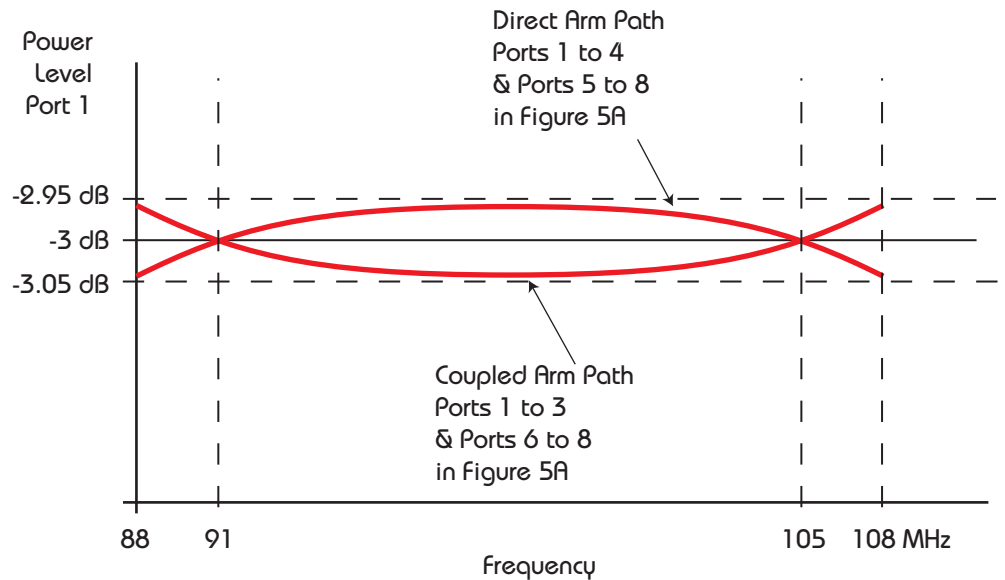

Figure 6. Hybrid Frequency Response

## The Bandpass Filter

Modern balanced combiner station modules employ two bandpass filter sets between

the input and output hybrids. In complex combiner systems it is imperative that the bandpass filters of all modules be tuned to have as close to the same response characteristics as possible. The goal is to have the hybrids react identically to the filters. Small differences in electrical length through the hybrids quickly add up to an increased VSWR. For example, a phase difference of  $\pm 2^\circ$  in the legs of a hybrid produces a VSWR of 1.07:1 (-29 dB). If that phase difference degrades to  $\pm 4^\circ$ , the VSWR deteriorates to 1.15:1 (-23 dB).

## Types of Bandpass Filters

Balanced combiner bandpass filters come in three designs: loop-coupled, iris-coupled, and interdigital. The designs refer to the method used to couple electrical energy between the individual cavities of the filter. Loop-coupled cavities are generally round and rely on interconnecting coax to obtain a quarter wave of electrical length between the center probes of adjacent cavities. As the size of the cavities increases in proportion to their required power handling capacity, and/or the spacing that needs to be maintained becomes shorter at higher frequencies, mechanical interference becomes a problem. When this occurs, the input and output coupling loops of the cavities are altered to compensate.

Ideally, the input and output coupling loops should be as close to identical as possible to ensure that the phase and amplitude of the energy entering and exiting the cavity are as close to identical as possible. Loop-coupled filters typically provide a large number of tuning points allowing compensation of phase and amplitude discrepancies. However, as stations are added to the combiner and the number of (different frequency) bandpass filters that must be identically tuned increases, the sheer number of parts and adjustment points moves from being an asset to a hindrance. This is because the chances for mechanical, electrical, and thermal asymmetry increase with the square of the number of filters as the relationships between pairs of stations must be taken into account. For this reason, large loop-coupled combiner systems typically require large amounts of final tuning after the modules have been moved into place and each time a new module is added. Loop-coupled bandpass filters also have the disadvantage of being much larger than their iris-coupled counterparts, often as much as twice as large.

In iris-coupled filters, cavities are square and physically joined together in rectangular boxes. Adjacent cavities share an iris wall. Currents circulating around the center probe of one cavity induce alternating currents in the adjacent cavity, providing  $90^\circ$  quadrature without manipulation of the physical spacing. The elimination of the intercavity connecting coax

and coupling loops not only eliminates the chance of phase and amplitude distortion, but also reduces the parts count of the cavities significantly. This, in turn, makes iris-coupled cavities less susceptible to thermal detuning and easier to thermally stabilize. Iris-coupled cavities rely on the cavity being designed and fabricated to very tight mechanical and electrical tolerances, something that was difficult before the advent of modern computer design programs.

Interdigital filters have only recently been introduced as an alternative to loop- and iris-coupled filters at FM frequencies. Interdigital filters do not employ individual cavities that must be coupled together. Parts counts are minimized and interdigital filters are significantly smaller than even iris-coupled filters. Because of their smaller size, interdigital filters have higher insertion losses than either loop- or iris-coupled filters of the same power rating, and careful attention must be paid to the thermal properties of the filter. Interdigital filters have better out-of-band frequency rejection than cavity style systems and are ideal for balanced combiners because of the ease of maintaining identical tuning across the system.

Combiners with stations that are close in frequency or where future close-spacing is possible generally utilize four-cavity/resonator bandpass filters. Adding resonators or cavities to a bandpass filter increases rejection (isolation) and the size of the passband (Figure 7). Improved pass-band width is becoming increasingly important for digital operation. However, it also increases group delay, insertion loss, and physical size of the filter. Optimizing the tuning of a filter for any one of these characteristics tends to degrade the others. In complex systems, isolation is the most important characteristic of a filter. Group delay can be overcome with equalizers and insertion loss is compensated by increasing transmitter power.

For combiners with relatively large frequency spreads, 2- and 3-cavity bandpass filters are sometimes used to save cost and space. Occasionally, frequency spreads between stations in the combiner chain are artificially increased by splitting the combiner into two separate combiners and assigning adjacent frequencies to opposite chains. Each combiner then feeds the antenna through a separate transmission line. This system is particularly common in countries where frequency spreads of less than 0.8 MHz can be found in a market. This method of combining makes incorporation of separate digital transmitters difficult, if not impossible, depending on the frequency spread.

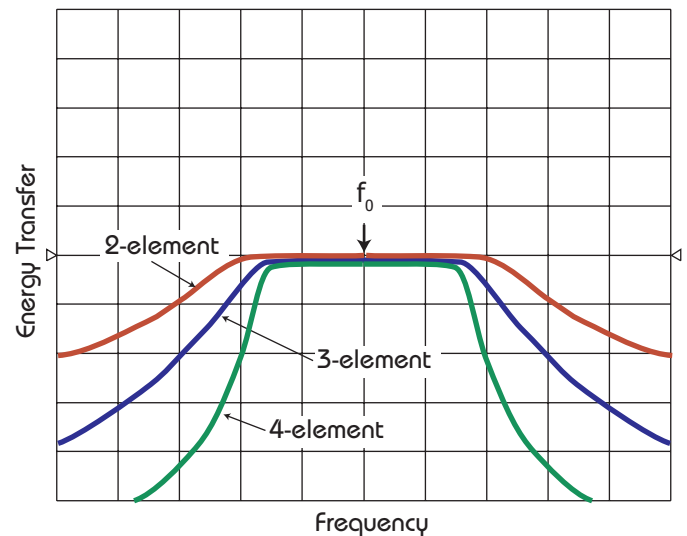

Figure 7. Frequency Response for 2-, 3-, and 4-Element Bandpass Filters

## Input Hybrid Load

When only one port of the input hybrid is being used, the other is normally occupied by a reject load. The size of this load depends on the isolation between the input ports of the input hybrid, typically about -35 dB for a modern hybrid. In a standard-feed combiner, all unattenuated power reflected from the antenna is shunted back through the station module to the transmitter input port. In back- or cross-feed combiners, the isolation inherent to the radiator design or the isolation between the two antennas must be taken into account. In a well-balanced radiator design, this antenna isolation will typically run in the 15-20 dB range. The unattenuated power in a back- or cross-feed combiner returns to the hybrid port opposite the transmitter input. Therefore, in these configurations the load must be sized to handle 15-20 dB more reject power than in a standard-feed configuration. If the radiator is poorly balanced and the isolation is lower, the size of the input hybrid load will need to be increased accordingly. The same considerations and calculations used to compute the size of this load are used to size the isolator load if one is employed for digital combining.

## Directional Couplers

Precision directional couplers are commonly found on each broadband output of balanced combiner systems. This directional coupler is a convenient port for taking FCC-required test measurements, enabling diagnostics and as a port for any protection and monitoring system the combiner may employ. Its versatility is further enhanced when it is used with directional couplers located on the inputs to each module. Couplers must be of high quality to ensure proper operation in the complex combined environment.

## Group Delay and Equalization

When the entire 200 kHz wide group of frequencies that compose an FM channel passes through a filter, it doesn't do so at the same time. The portions of the signal (or frequency groups) farthest from the center frequency (represented by  $f_0$  in Figure 8) are delayed. It is desirable to have the delay as symmetrical as possible.

When two frequencies in a combiner chain are located close together (generally 1.0 MHz or closer), their bandpass filters interact causing an asymmetry in the frequency response of the filters, which in turn causes the frequency groups in portions of the signals to travel through the filter at different rates. These resulting asymmetries in signal speed are referred to as group delay. It is possible to correct for group delay by asymmetrically tuning the filters to compensate for the differences in frequency response. However, this has the effect of unbalancing the station module, decreasing the isolation, and increasing the amount of power to the reject load. Instead, modern combiners use additional, specially tuned cavities to return the group delay across the channel to a more symmetrical pattern. The equalizer is needed only for the station in a closely spaced pair that is located farthest from the wideband output. Group delay correction is only used on the analog portion of signals. In back- and cross-feed combiners that allow feeds to be reversed, the group delay equalizer must be tuned in the position the station module will normally occupy and it must be removed from the transmission chain if the feed is reversed.

Modern combiners normally employ low-level group delay equalizers positioned between the output of the station's exciter and the input of the IPA of the transmitter. Older systems generally located the equalizers between the transmitter and the input of the station modules. These older group delay equalizers were larger in order to handle more power and took up significantly more space. However, they had the advantage that the spacing between the group delay equalizer and the combiner module could be optimized to maximize VSWR bandwidth.

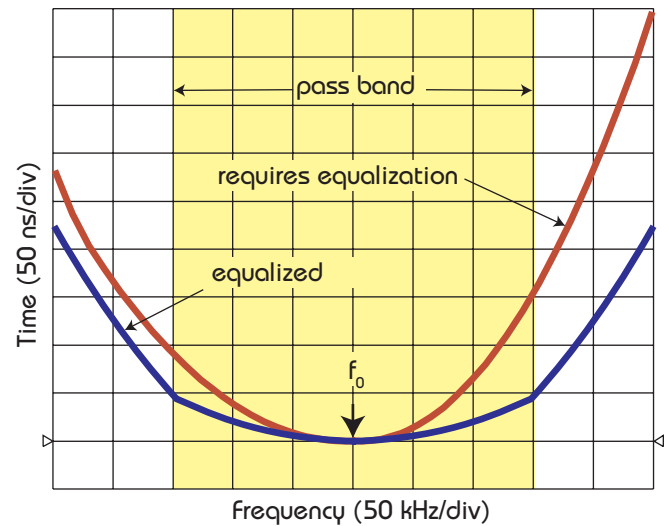

Figure 8. Group Delay Equalization, Before and After

## Lockout/Tagout

Modern combiner systems generally supply lockout/tagout capabilities. This is particularly important for systems that allow remote startup of transmitters and where the transmitters may be under the control of multiple engineers. Lockout/tagout is generally accomplished by employing a short from the outer conductor to the inner conductor of strategically placed coaxial transmission lines.

The broadband lines between the combiner output(s) and the antenna provide a logical place to lockout power from the antenna with a minimum number of switches. However, this only provides safety downstream toward the antenna. It is becoming increasingly common to see lockout/tagout done on transmitter inputs, particularly on back- and cross-feed systems. While this requires locking and monitoring of more points, it has the advantage of allowing only some transmitters to be locked out in the event that just one broadband feed is shut down. It also provides protection when work is being done on the combiner rather than the antenna.

## Conclusion

Combiners have been used for many years to allow the transmission of multiple signals over a single antenna. However, with the implementation of HD Radio™, the need to keep combiners as small as possible, and the desire to provide redundant transmission paths in a single antenna, combiners are becoming increasingly complex. While the fundamental components of balanced combiners remain the same, this increasing complexity requires that these components be manufactured and tuned to increasingly sophisticated standards.