

## Introduction to Cross-Coupling in RF Filter Design

by Robert A. Surette and Robert F. Liebe © 2000

### Abstract

A filter design needs to take into account physical concerns such as size, weight, and cost, as well as performance considerations, including isolation, loss minimization, and group delay. We always design a filter for the best real-world overall combination of all these characteristics, and almost always we have to sacrifice a little performance in one parameter in order to improve another, such as the tradeoff of insertion loss and isolation in all-pole designs. In many cases, cross coupling allows us to keep these sacrifices to a minimum.

Document No. *tb-cross-coupling (0610)*

A Division of Howell Laboratories, Inc., P. O. Box 389, Bridgton, Maine 04009 USA  
(207) 647-3327 1-888-SHIVELY Fax: (207)647-8273  
*An Employee-Owned Company*

www.shively.com  
sales@shively.com  
*Certified to ISO-9001:2000*

## RF Filters

An RF filter sorts RF signals, attenuating some frequencies while allowing others to pass. In doing so, it performs three basic functions:

- it passes the signal that you wish to broadcast,
- it keeps you from interfering with signals of others, and
- it keeps others from interfering with your signal.

Depending on the design, a filter may either attenuate (band-reject type) or pass (band-pass type) a specific narrow bandwidth. Conventional RF filter design practice is to use a series of coupled resonant sections to increase the selectivity of the filter and broaden the desired band to allow room for sidebands.

Figure 1 shows a couple of typical single-section band-pass filters. Figure 2 shows a four-section band-pass filter.

### Coupling

The coupling between resonant sections can be achieved and modeled in a number of ways, one of which is shown schematically in figure 3. A phase shift of  $\pm 90^\circ$  is created as the signal passes through the coupling structure and into the next resonant section. This phase shift is due to the admittance/impedance inverting properties of the coupling structure and, through tuning, is how we create the desired bandwidth in the filter.

Without proper coupling, the cavities would act as a single resonator with a slope parameter equal to the sum of the individual resonators.

### Frequency Response and Isolation

A common way to measure the performance of a filter is the frequency response diagram. Figure 4 is a diagram showing the frequency response of several theoretical band-pass filters. Note the "plateau" constituting the pass band, where the attenuation is very low, and the sharp drop-offs at the edges of the plateau, indicating that frequencies outside the pass band are effectively attenuated, or isolated.

As resonant sections are added, the transition at the -3dB edge of the pass band yields sharper drop-offs, or more effective isolation.

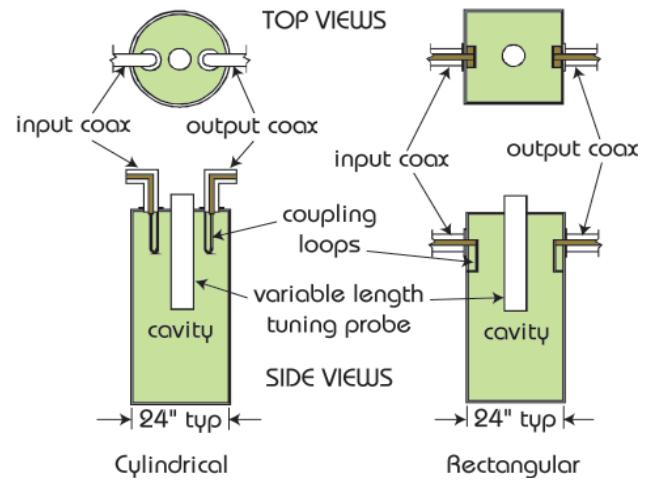

Figure 1. Typical Band-Pass Filter Construction

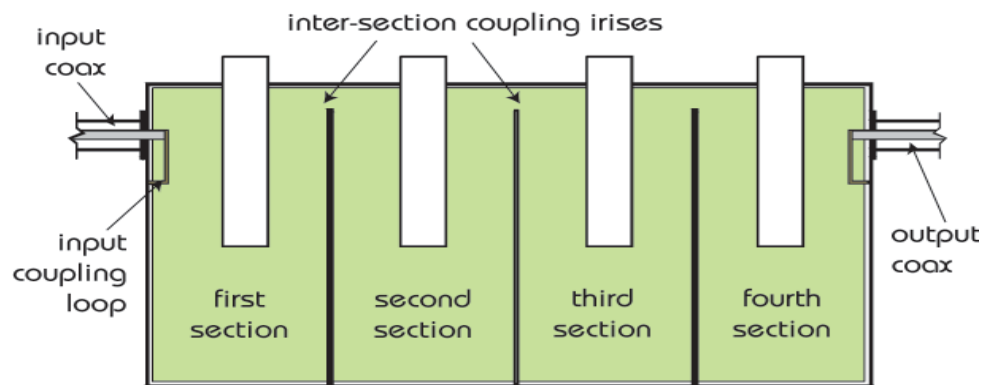

Figure 2. Typical Four-Section Band-Pass Filter

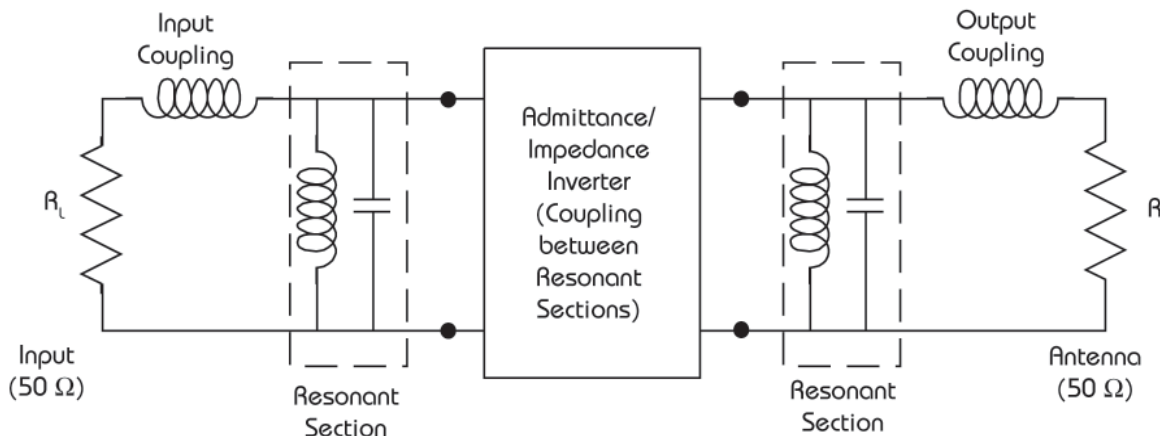

Figure 3. Coupling Between Filter Segments

## Meeting Today's Tighter Specifications

For years, the FM channel was relatively simple, with only the carrier and a stereo pilot. In the mid-1980s, the 67 kHz SCA (Subsidiary Communications Authorization) became more widely used; then the 93 kHz SCA followed. The mid-nineties have brought DAB (digital audio broadcast). Each of these developments has increased utilization of the frequencies within allotted bandwidths.

Thus, improved filter performance is necessary to meet today's tighter specifications. But improving the frequency response comes with tradeoffs:

### Insertion Loss

Although the transfer of energy through the filter is at a maximum at the center frequency, energy transfer is not perfect and some energy is lost in the process. The lost energy is turned into heat and dissipated within the resonant section. The measurement of how much energy is dissipated, measured in dB, is called insertion loss. Some factors that determine how much energy will be lost are the  $Q$  (quality factor) of the components in the filter, the bandwidth of the filter and the number of resonant sections.

Figure 5 shows how both the isolation and the insertion loss increase with the number of resonant sections.

### Group Delay

The signal takes a finite amount of time to pass through the filter. This delay is least at center frequency ( $f_0$ ) and increases as we get further away in both directions. Today's complex broadcast signals use the full channel bandwidth; so it is important to minimize group delay difference.

When looking at a group delay diagram (figure 6), it is important to realize that the slight rise in group delay at center frequency is not significant; it's the difference in group delay between center frequency and the edges of the pass band that can cause signal distortion.

### Filter Size and Cost

As we add sections the filters become much larger and more cumbersome, and the cost increases with the increase in materials - not to mention the problem of getting one up a flight of stairs or up to the 80<sup>th</sup> floor in an elevator!

### The Upshot

As the specifications tighten and the filter must be increasingly selective, the tradeoffs in filter performance, cost, and size may become prohibitive and alternative filter designs must be investigated.

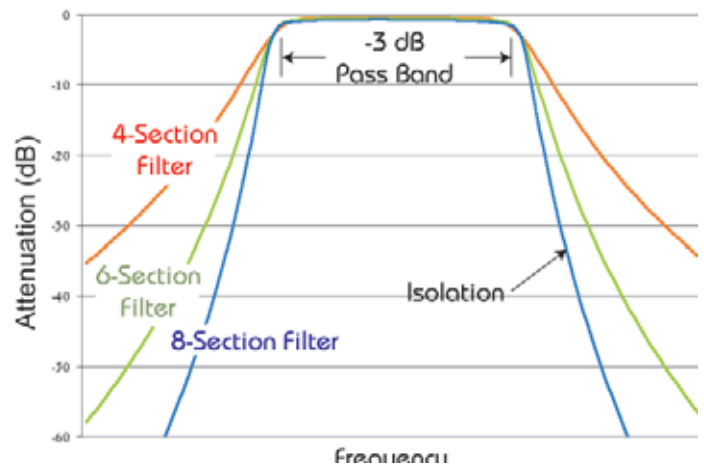

Figure 4. Frequency Response, Theoretical Band-Pass Filters

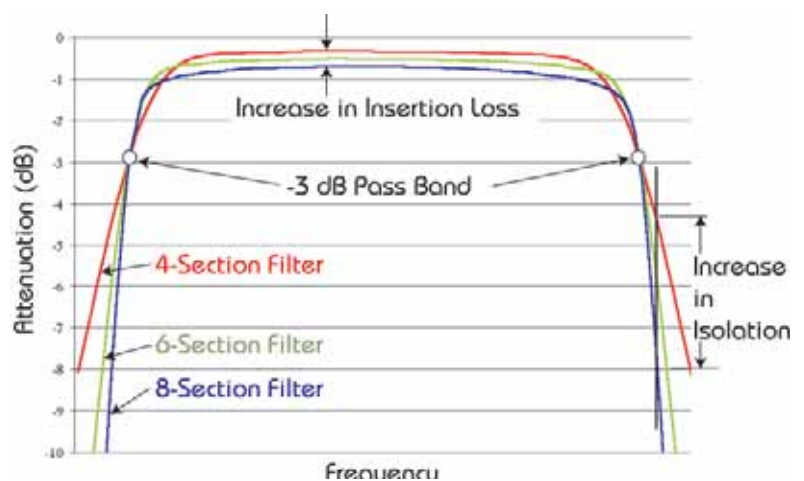

Figure 5. Insertion Loss Increases with Additional Resonant Sections

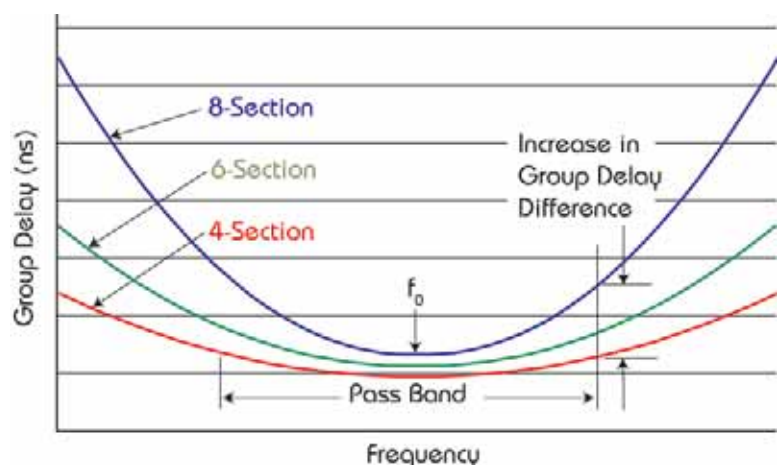

Figure 6. Group Delay Difference Increases with Additional Resonant Sections

## The Math

### Poles and Zeros

How can we express a filter's performance mathematically? In filter design and synthesis, transfer functions are used for this purpose. The derivation of a specific transfer function for filter synthesis requires in-depth circuit analysis and modern network theory, which is beyond the scope of this paper. However, in general, the transfer functions are a ratio of two polynomials of the complex frequency  $s$ , defined as:

$$s = j\omega$$

where  $j$  is the square root of  $-1$  and  $\omega$ , the frequency in radians per second, is  $2\pi f$ .

From the generalized filter in figure 7, where we have a voltage source  $\epsilon_s$ , a source resistance  $R_s$ , and a load resistor  $R_l$ , the transfer function would be stated as

$$T(s) = \frac{\epsilon_l}{\epsilon_s} = \frac{N(s)}{D(s)} = \frac{C(S-S_1)(S-S_3)(S-S_5) \dots}{(S-S_2)(S-S_4)(S-S_6) \dots}$$

where  $C$  is a real constant,  $S$  is the complex variable defined above, and  $S_x$  are the roots of the polynomial. The roots of the denominator  $D(s)$  are the frequencies at which the transfer function becomes infinite, and are called poles. The roots of the numerator  $N(s)$  are the frequencies at which the transfer function becomes zero and are called zeros. These complex frequencies can be plotted for evaluation and further transformation in the complex frequency plane as illustrated in figure 8, where each pole is represented by an  $x$  and each zero by an  $o$ .

Each pole and zero is achieved with a resonant section - an LC (inductive-capacitive) circuit or cavity. The number of resonant sections needed is thus determined by the complexity of the response required.

### The Circus Tent Analogy

To gain a general idea of how poles correlate to frequency response, we can think of the frequency response of a filter as a "circus tent." As shown in figure 9, the poles, each one created by a resonant section, hold up the top of the tent (the passband) while the sides of the tent drop away.

Indeed, if we plot a frequency response with VSWR on the same chart for the same filter, it's easy to see that the poles, which show up as dips in the VSWR, support the canopy of the frequency response.

### The All-Pole Filter

The standard band pass filter design that we've considered so far is a special case known as an all-pole filter, for which the math analysis contains no roots in the numerator. The frequency response therefore shows no zeros - or more precisely, the zeros are located approaching  $\pm$  infinity. Hence, the "slopes" of the frequency response diagram taper off steadily as we move away from center frequency (figures 4 and 9).

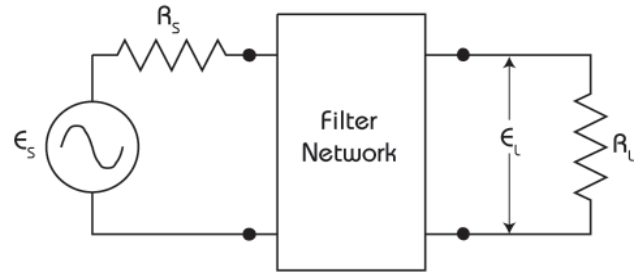

Figure 7. Generalized Filter Network, Schematic Diagram

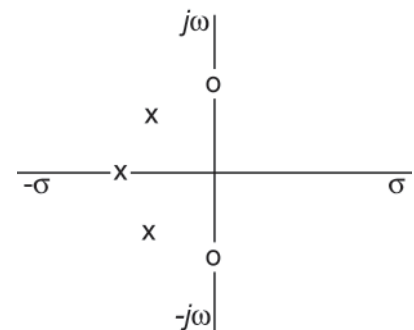

Figure 8. Poles and Zeros in the Complex Frequency Plane

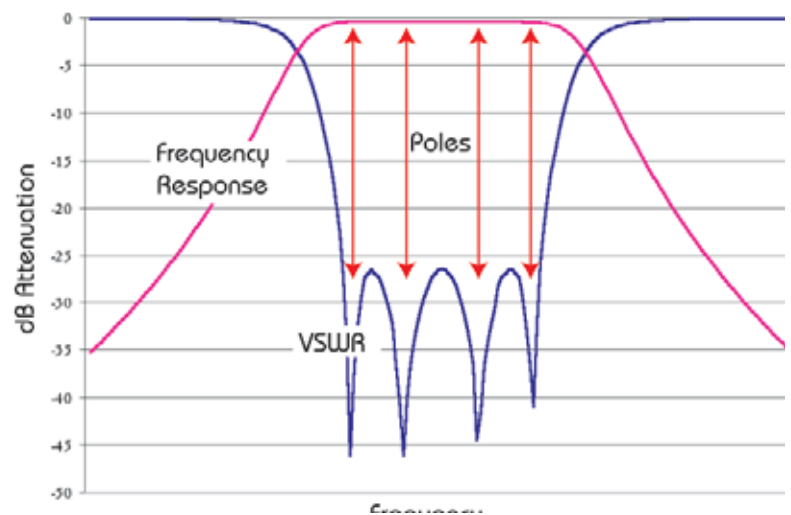

Figure 9. Correlation of Poles and Frequency Response

## Other Solutions

If we could create zeros near the edges of the pass band, we could force the frequency response transition to be sharper. One way to do this is to add "band-reject" sections - that is, sections that are tuned to reject a specific frequency instead of passing it - for example, to use a six-section filter (figure 10) where two of the sections are used as band-reject sections. A filter such as this can be tuned so that the zeros are close to the pass band, increasing isolation and decreasing the attenuation across the pass band compared to a six-section all-pole design (figure 11).

Since the amount of energy dissipated in the band-reject sections is much lower than that passed through the filter, we could make the band-reject sections a smaller size. Also, these could be coupled using cable and would be separate from the filter itself. While these construction features make this option more viable, cost and size remain a factor due to the added sections.

We can avoid these drawbacks of size, cost and insertion loss with cross coupling.

## Cross Coupling

In the filter shown in figure 10, we have increased isolation by adding two band-reject filters to our basic four-section band-pass filter. In doing so, we have added substantially to the overall size of the filter, and also increased insertion loss due to the energy dissipated by the extra sections.

If instead we add a transmission line segment between the first and last band-pass sections (figure 12), we create a parallel transmission channel. This line segment is then tuned to achieve specific phase and magnitude characteristics, so that unwanted frequencies at both ends of the filter cancel each other out. It therefore acts as a band-reject component, creating zeros at the edges of the pass band similar to those shown in figure 11.

The extra bulk and cost of the added reject sections is eliminated, and the increase in insertion loss that occurred is now kept to a minimum, because we no longer have the power dissipation in the extra resonant sections.

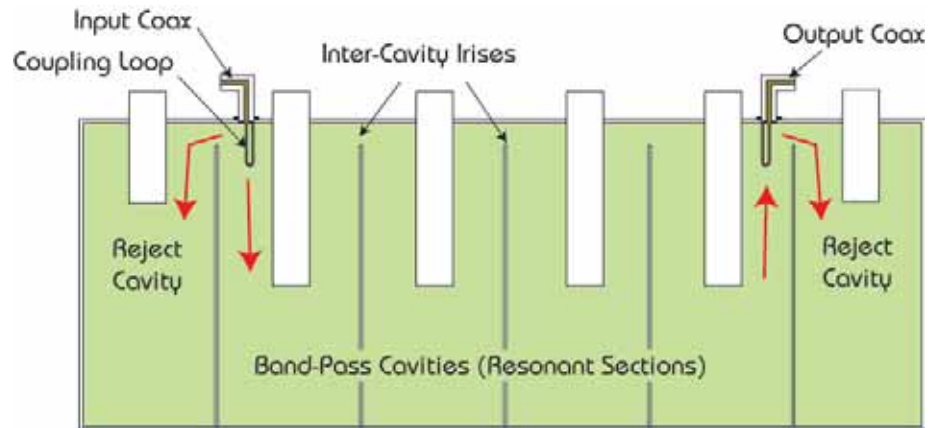

Figure 10. Filter Consisting of Four Band-Pass Sections and Two Band-Reject Sections

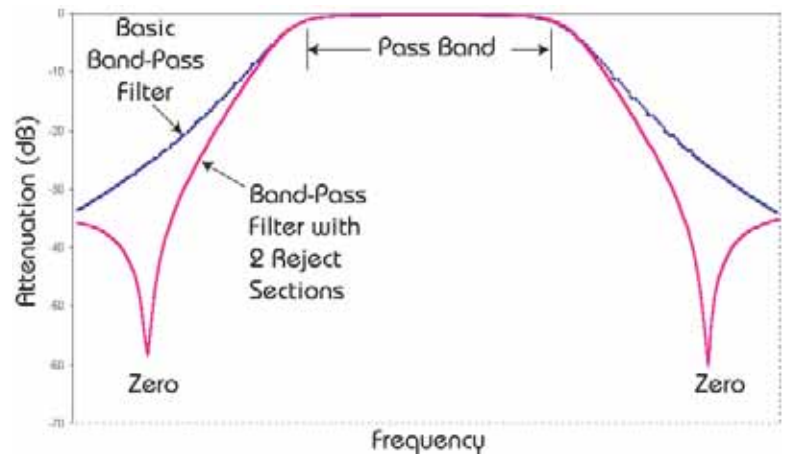

Figure 11. Effect of Adding Two Reject Sections to Basic Band-Pass Configuration

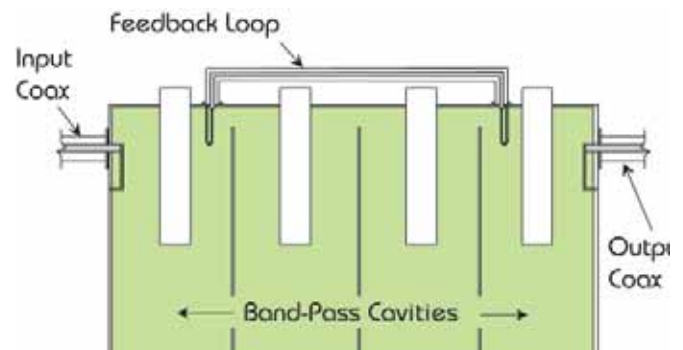

Figure 12. Typical Cross-Coupled Filter Construction

## Tuning

Tuning of cross-coupled filters is critical. There is a delicate balance between the placement of the zeros and the coupling factors within the filter, and without careful tuning of both the filter and the cross coupling, a less than optimal response will be attained. In figure 13 we can see the difference between an optimized filter and one that is not properly tuned.

Although it takes more time to reach the desired tuning in a cross-coupled filter, the end result is a filter that has better transmission characteristics.

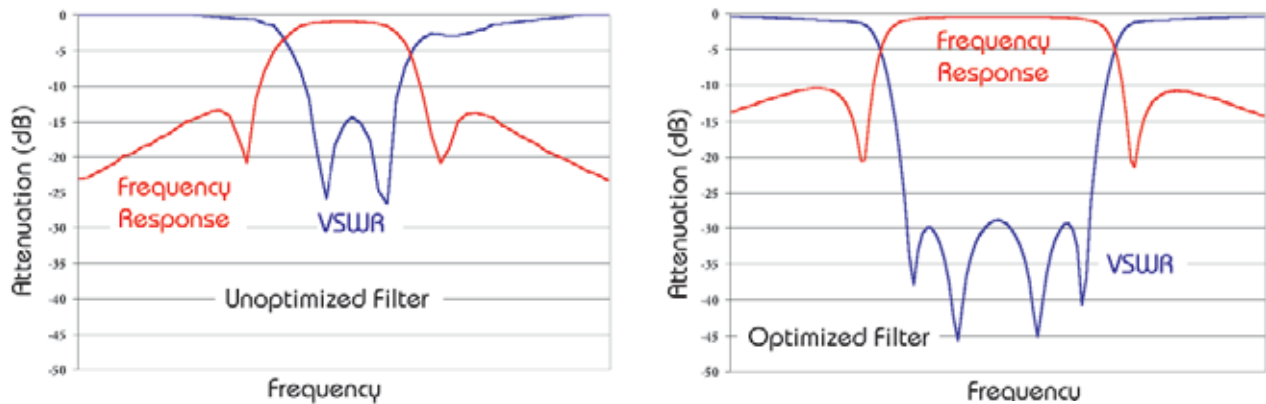

Figure 13. Frequency Response and VSWR for the Same Filter, Unoptimized and Optimized

## Conclusion: A Real-World Example

A typical IBOC transmitter uses frequencies at  $\pm 100$  to  $200$  kHz from center frequency, and needs  $-20$  dB isolation at  $\pm 300$  kHz. Thus, this isolation needs to occur in the  $100$  kHz spans between  $\pm 200$  and  $\pm 300$  kHz. For this purpose, a four or six-section band-pass filter alone won't do the job; a four-section cross-coupled band-pass filter is the solution.

## References

Williams, Arthur B. and Fred J. Taylor. *Electronic Filter Design Handbook*, Third Edition. New York, McGraw-Hill, 1995.

Matthaei, George L., Leo Young, E. M. T. Jones. *Microwave Filters, Impedance Matching Networks, and Coupling Structures*. Norwood, Massachusetts, Artech House, Inc., 1980.