

Low-Level Digital Combining for Multi-Station Installations

Existing Shively Model 6014 antennas and Model 2540 balanced combiners can be modified to handle IBOC/HD Radio, with several small changes. Both the combiner and antenna can be modified after the equipment is installed.

The IBOC conversion consists of:

- A "Digital Feed" for the antenna system.
- 1 or 2 runs of 1-5/8" heliax transmission line for the digital feed.
- A 1-5/8" hybrid power splitter for the digital transmission lines, if dual feeds are desired.
- A 1-5/8" output directional coupler for digital broadband line.
- One isolator per station at the digital input to the combiner.

In experiments carried out at the Entercom Cougar Mountain facility in Seattle during the

summer of 2002, we showed that the balanced combiner system can isolate digital and analog feeds simultaneously. This is done by feeding the digital signal into the system through the input hybrid port normally occupied by a small dummy load. In addition, each station requires a small isolator. Some stations may also require an additional IBOC bandpass filter, but this will depend on the performance specifications of the transmitter in use. The digital signal passes through the combiner system along the broadband line, 180° opposite the path of the analog signal, and exits through the broadband input of the module farthest from the analog output. The system load normally occupying this port is removed. This arrangement is shown in Figure 1 above.

This process works well for any number or combination of stations. Further, running some stations with digital signals and some without does not unbalance the system or cause interference.

Document No. tb-llcat (0611)

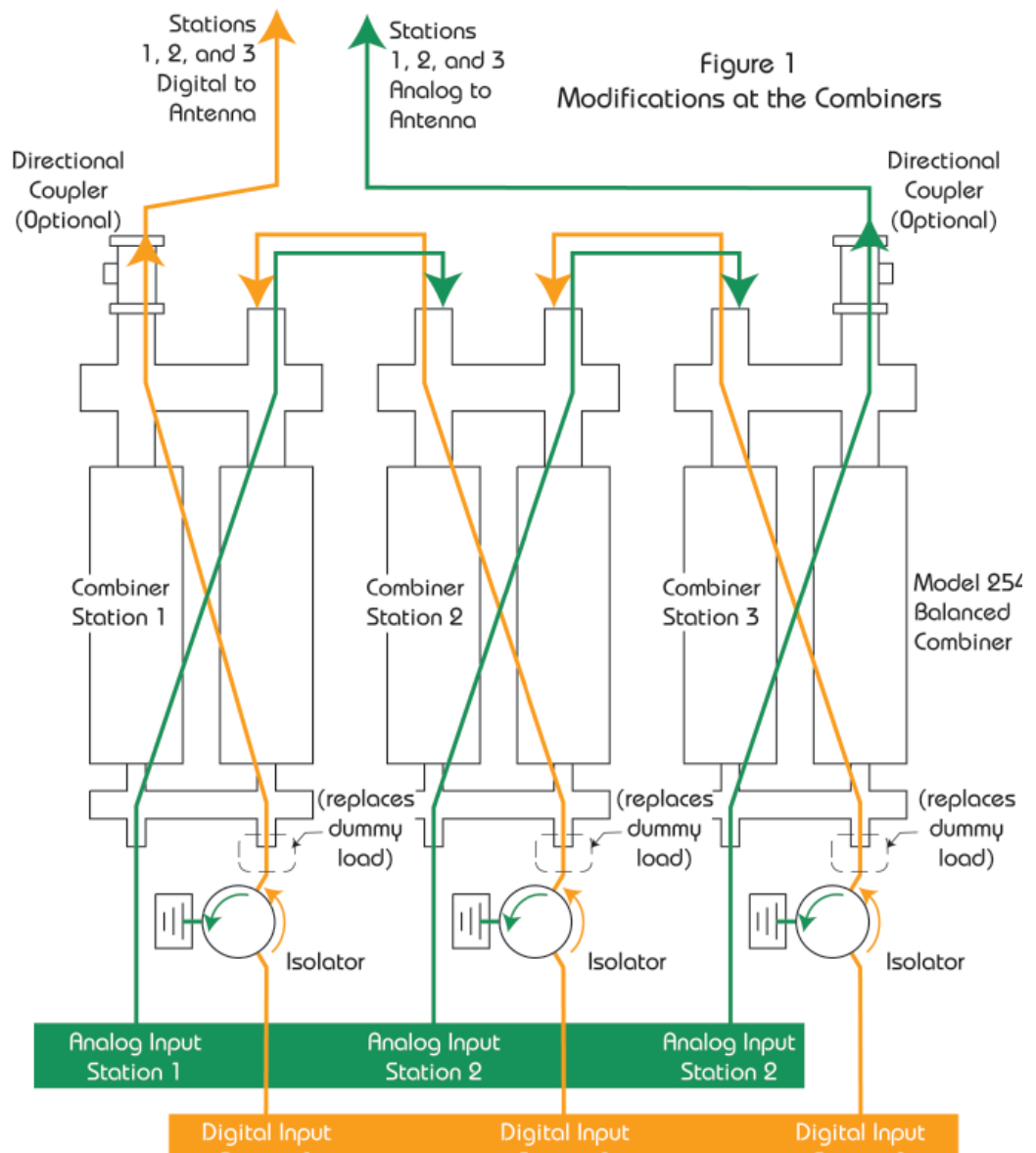

A 1-5/8" output directional coupler may be added to the digital broadband line as shown, for use in diagnostics and tests.

At the antenna, the digital feed is identical to the analog feed, but smaller because of the much reduced power level. The digital signal is fed into the bays through the hybrid ports normally occupied by small dummy loads, as shown in Figure 2 at right.

The average digital power is 1% of the average analog power. For example, a 4-station system running 10 kW average analog TPO's (40 kW total) would require approximately 400 watts of combined digital power.

A single run of 7/8" transmission line can easily accommodate the combined digital feeds of almost any multi-station installation, but 1-5/8" transmission line will probably be used at most sites to minimize losses.

For antennas designed with dual feeds to allow the antenna to operate independently on upper and lower halves, a dual digital feed must be used or the digital system will not work if the antenna is operated in a half-antenna mode.

In a dual feed system, the digital broadband line is split into two feeds, using a hybrid power splitter just like the one in the analog feed, but smaller.

The power dividers in the digital feed add a small amount of windload to the antenna system, but in general the feed will occupy little space in the tower, because of the small size and bending radii of the feedlines.

The power dividers in the digital feed add a small amount of windload to the antenna system, but in general the feed will occupy little space in the tower, because of the small size and bending radii of the feedlines.

Finally, the digital feed can easily be physically isolated from the analog feed to prevent loss of pressurization in one feed system if the other is damaged.

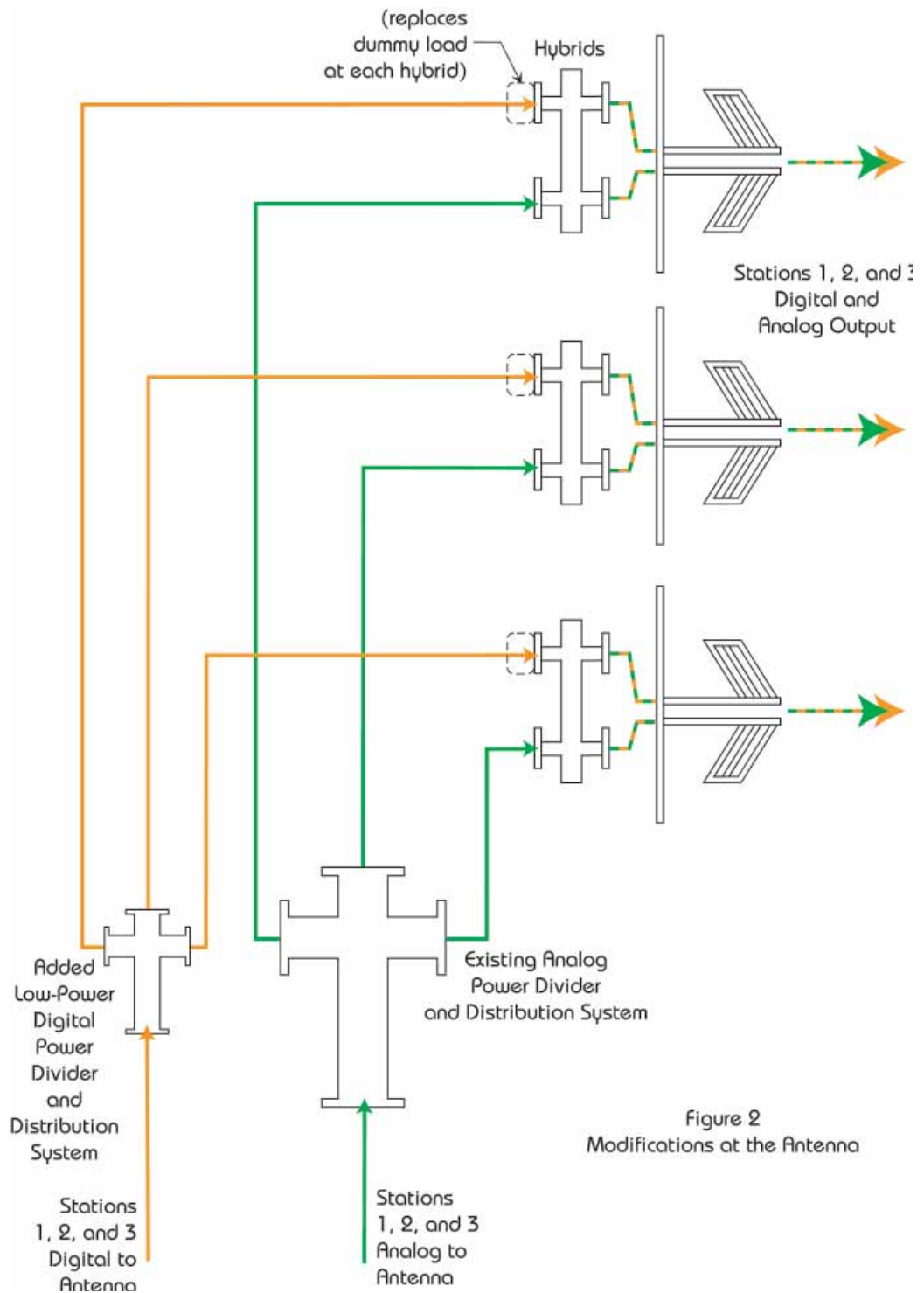

Figure 2
Modifications at the Antenna