

## Converting a Bottom-fed 6814-2 Antenna into a Center-fed 6814-4

This tech sheet describes the field addition of two bays to a bottom-fed 6814 two-bay antenna so as to convert it into a center-fed 6814 four-bay. Follow these instructions carefully to ensure successful conversion.

### CAUTION

The new antenna will extend down the tower approximately 20 feet (6 meters) farther than the old one. It is the owner's responsibility to ensure that the antenna will not conflict with guys or other tower components.

### NOTE

In going from a bottom-fed antenna to a center-fed antenna, the attachment point of the transmission line is shifted to one side. If semi-flex transmission line is used, it may be possible to bend it to reach the new attachment point; if your transmission line is rigid, you must provide additional line sections to achieve this shift. These parts are not included with the conversion kit.

See the assembly illustrations. Figure 1 shows the antenna before the conversion; figure 2 shows it after the conversion. See also the enclosed owner's manual as applicable; it describes radome installation, deicer wiring, and other information you may need .

- a. Turn off the transmitter and the deicer, if applicable, and tag and lock them out on the ground, to prevent their being turned back on inadvertently.
- b. Remove antenna bay #2 (the lower one) from its L section. You may have to remove the radome to remove the antenna bay. Save the bay for reinstallation.
- c. Remove the L section and discard it.
- d. Remove the transformer and save it for reinstallation.

### CAUTION

In all cases when connecting line segments, be sure the inner conductor connectors are installed properly, and that each outer conductor flange contains an O-ring to exclude moisture from the air outside.

- e. Install the new L section provided with the conversion kit.
- f. Reinstall the bay you removed in step 2 onto the new L section. Reinstall the radome if applicable.
- g. Install the T section at the bottom of the L section, with the long arm extending toward what will be the transmission line attachment point.

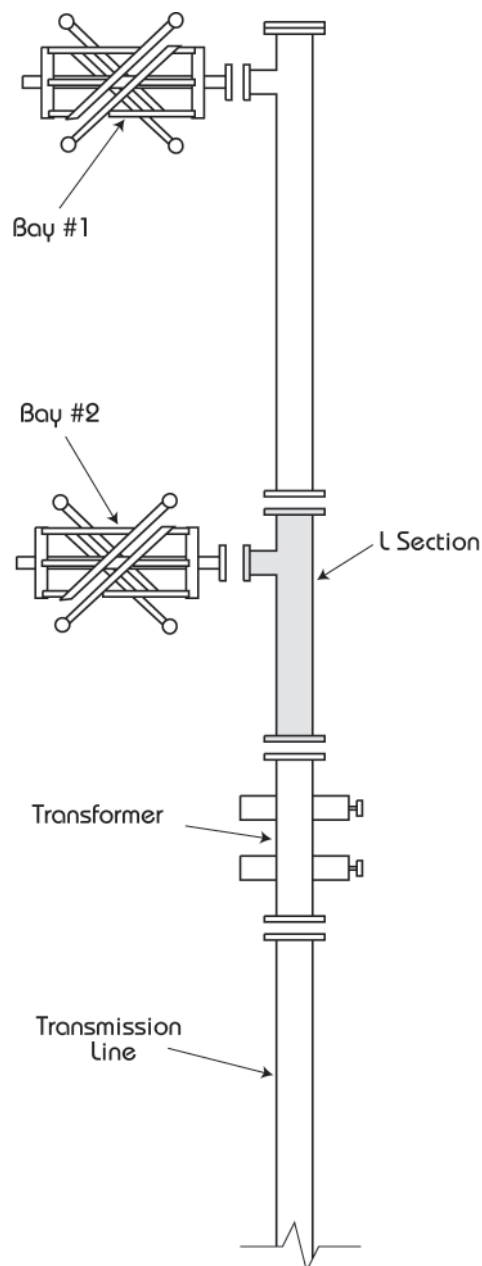

Figure 1. Antenna Assembly Before Conversion  
(shaded indicates parts removed)

Document No. ts-6814\_2bay\_to\_4bay (0611)

## CAUTION

The short transmission line section's inner conductor is not secured within the outer and can slide out. Be careful when handling this section. If the inner comes out, be sure it is reinstalled with the hand-marked red arrow pointing upward.

- h. Install the short transmission line section at the bottom of the T section.
- i. Install the feedline section provided with the kit at the bottom of the short transmission line section.
- j. Install the short brass baymount section at the bottom of the feedline section installed in step 9.
- k. Install antenna bay #3 on the feedline section installed in step 9, then bay #4 on the short brass baymount. Install their radomes if applicable.
- l. Install the transmission line elbow provided with the kit onto the horizontal end of the T section installed in step 7.
- m. Install the transformer at the bottom of the elbow.
- n. Connect the transmission line to the bottom of the transformer. Additional parts may be required to match the transmission line to the new attachment point; this is your responsibility.
- o. Reconnect the deicer system if applicable.
- p. Start the antenna up in accordance with Chapter 2 of the owner's manual. Follow all precautions. Be sure to perform all tests to ensure the antenna is operating properly before releasing it for service.

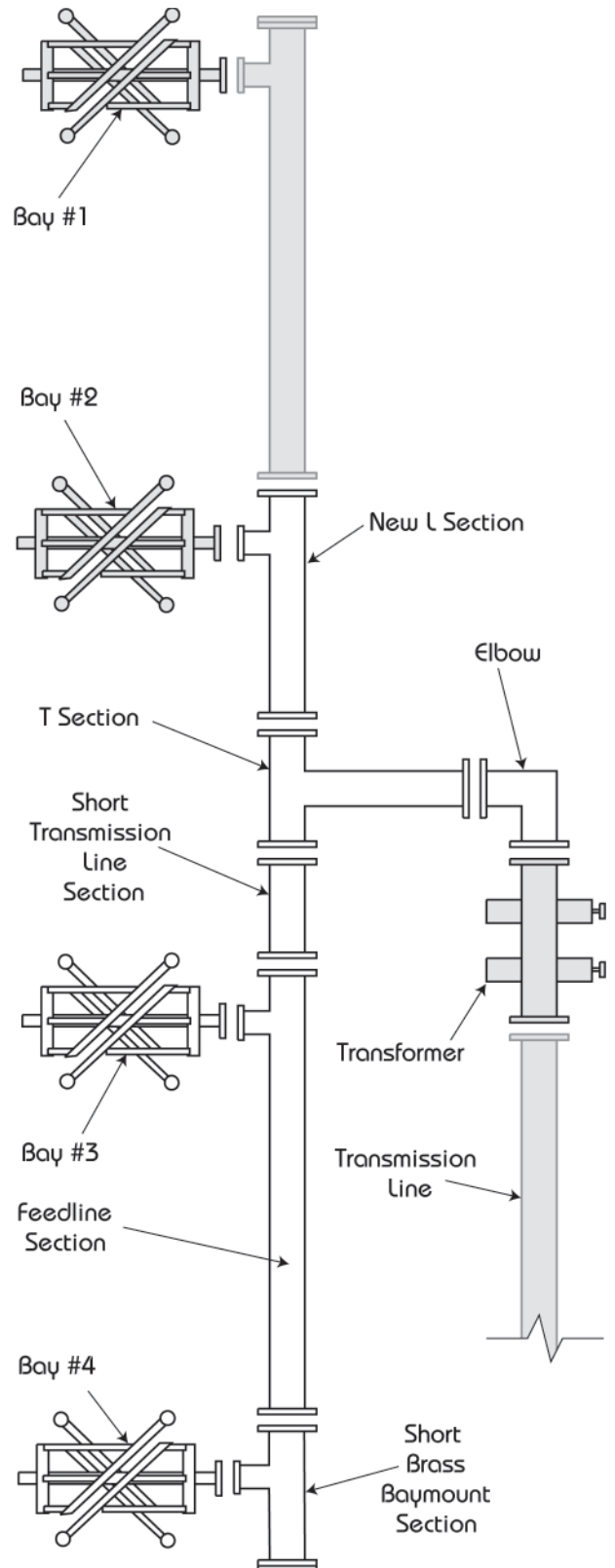

Figure 2. Antenna Assembly After Conversion (shaded indicates parts from original assembly)