

Installing De-Icers

The radome retrofit may be done on the tower. However, you may find it easier to bring the radiators down and do some of the work on the ground. Both methods are described below.

Precautions:

WARNING

Installation should be performed only by personnel experienced in RF systems, qualified in electric work, and familiar with this equipment.

The broadcast industry has recently recognized the potential medical hazards of intense radio frequency radiation. Don't expose personnel to personal harm. For reference, see CFR 29, Section 1910.97, the OSHA standard for exposure to non-ionizing radiation. Whenever a rigger is on the tower in the area of the antenna, shut off the transmitter and lock it off so that it cannot be turned on accidentally.

CAUTION

It is YOUR responsibility to ensure that your installation meets all applicable electrical codes. We recommend that the installation be reviewed by a qualified electrician before you apply power.

All parts of the de-icer system within about 20 feet (6 meters) of any radiator must be shielded from RF energy, and the entire outdoor portion of the system must be made waterproof.

Shively Labs's de-icer control box, Model 94068, is designed for interior installation only.

An improperly installed de-icer can overheat and damage your antenna.

Installation Information

Electrical Schematic Diagram:

The de-icer system consists of the heating elements in the bays, their branch cables, and the main harness. The main harness consists of a bay junction box for each antenna bay, interbay cables, and a "pigtail" of wires extending about 10 feet (3 meters) which you will connect to the tower junction box you are to provide.

Your system may also include specially-ordered items, such as a ground-mounted main control box, a power cable extending up the tower, or a tower-mounted thermostat.

A schematic diagram of the overall de-icer system is shown on the next page.

Thermostat:

CAUTION

Shively Labs deicers are designed to prevent ice from forming on antenna elements and are not designed to melt ice that has already formed.

For this reason, Shively Labs recommends that the system be installed with a dual setting thermostat assembly (Shively Labs Model 55522-G502) and controller assembly (Shively Labs Model 94068) that ensure the deicers are operated in the temperature range ice is most likely to form.

Electric Power:

The de-icer system requires 220 VAC, 50 - 60 Hz., single-phase. Tables in "Sizing of De-Icer Control Box and Wiring" show approximate heater leg resistances and current draws, respectively, for various models and configurations.

Document No.: [ts-de-icer_installation \(071126\)](#)

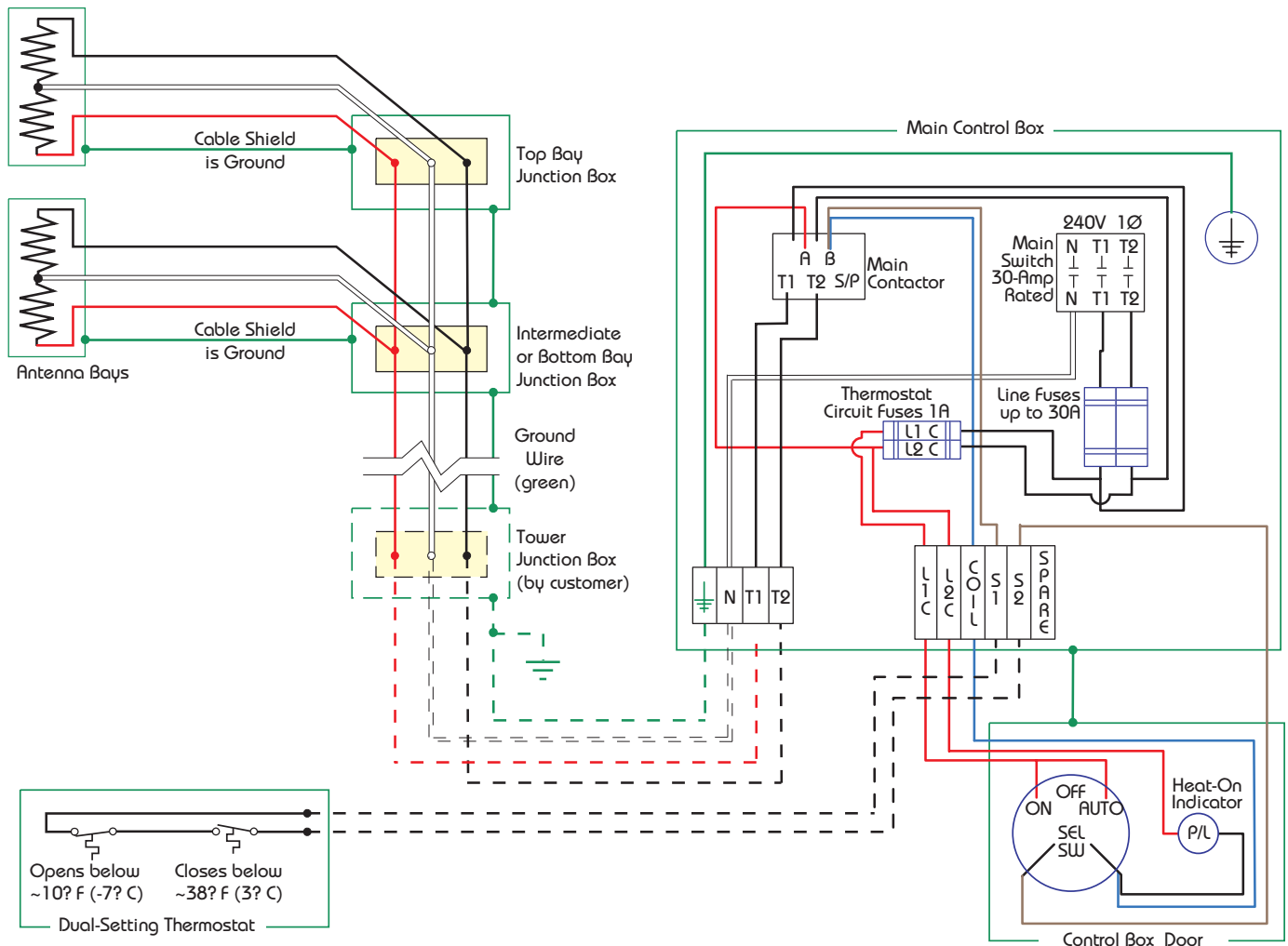

NOTES

Customer-supplied items are shown in broken lines.

A liquid-tight conduit connector (3/8" conduit size by 1/2" hub size) for the harness entry to the tower junction box, is packed loose with the de-icer harness.

Electrical Schematic Diagram, De-icer System

Installation Procedure

Install the de-icer harness:

- Install the main de-icer harness with its bay junction boxes as shown in Figure 1 and the schematic diagram of the overall de-icer system..
- (Center-fed antenna only) You may find that the feedline mounts are in the way when mounting the bottommost bay junction box. If necessary, using hose clamps, secure the bay junction box to the mounting bar provided, then secure the mounting bar to the feedline section. See Figure 2.

NOTE

Shively recommends the use of shielded braided polyethylene-covered wire or rubber-sheathed flexible metal conduit or rigid conduit and weather-tight fittings at all junctions.

- Connect the leads from each bay de-icer to the main harness in that bay's junction box as shown in Figure 1.

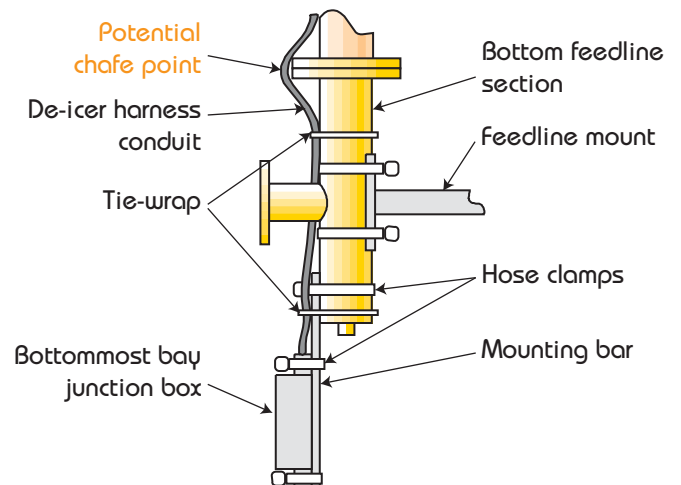

Bottom Junction Box Installation on a Center-fed Antenna

CAUTION

To prevent electrical short-circuiting, secure all cables to minimize wind-induced motion and chafing against edges of system or tower components.

- d. Secure any slack in these cables to the feedline with tie-wraps to prevent wind damage.

CAUTION

It is important that you ground both the tower junction box and the control box, as shown in Figure 1 and the schematic diagrams.

- e. Furnish a tower junction box as shown schematically in the schematic diagram.
- f. Using tie-wraps, secure the entire length of the de-icer harness to the RF feedline at about 24" (60 cm) intervals. Run the ten-foot pigtail along a feedline mount to the tower junction box and secure it to the mount and the tower.

Install the control box:

Furnish a main control box as shown schematically in the schematic diagram.. Shively's box is shown in Figure 3, but you may provide your own box if desired.

Install the thermostat:

If you are using a thermostat, you may locate it at your discretion. We recommend mounting it as closely as practical to the antenna.

CAUTION

When testing the thermostat, be sure to disconnect one or both thermostat leads before taking resistance readings. Otherwise, readings may be affected by other components.

- a. Before you connect the thermostat, measure the resistance across the thermostat circuit and from it to ground to ensure that there are no short-circuits. Thermostat readings should be as shown in Table 1 of "Installing the Shively Labs Model 94068 Dual-Setting Thermostat."
- b. Wire the thermostat to terminals S1 and S2 in the main control box.

NOTE

Wire sizes must account for the total current draw of the cable run to the antenna and the de-icer system itself.

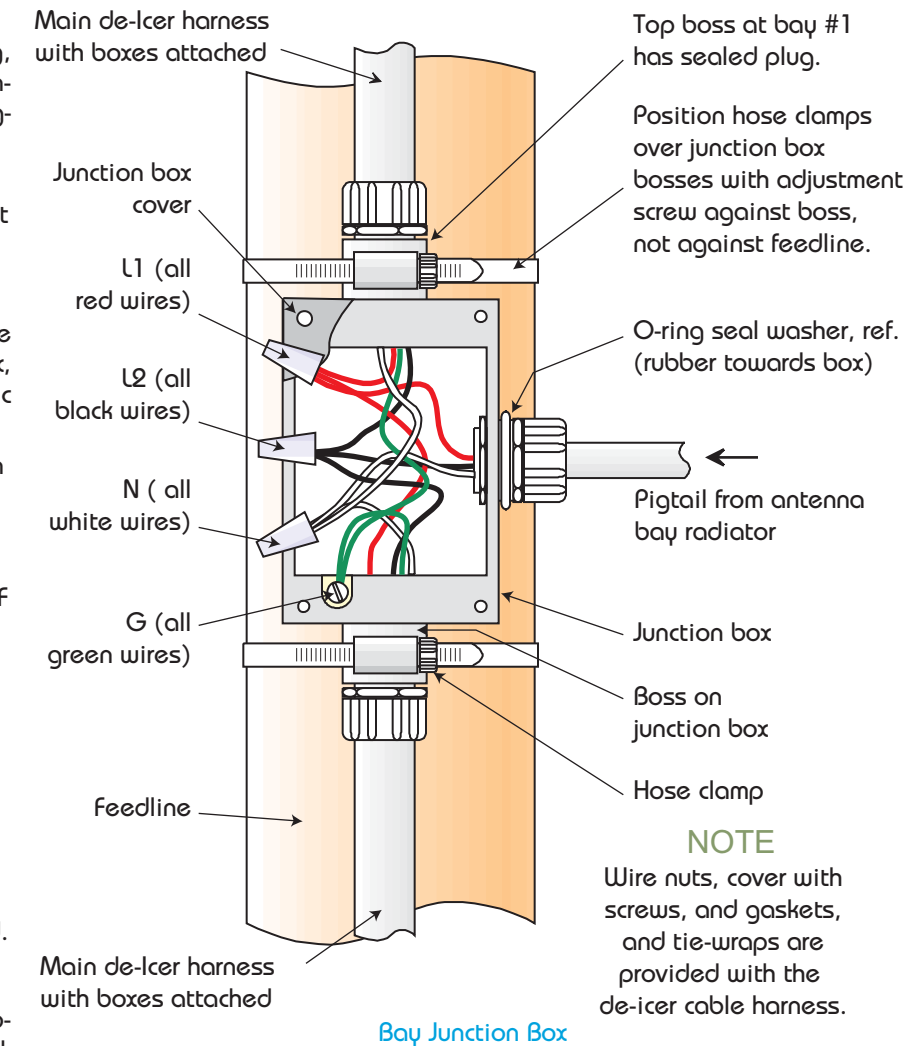

Bay Junction Box

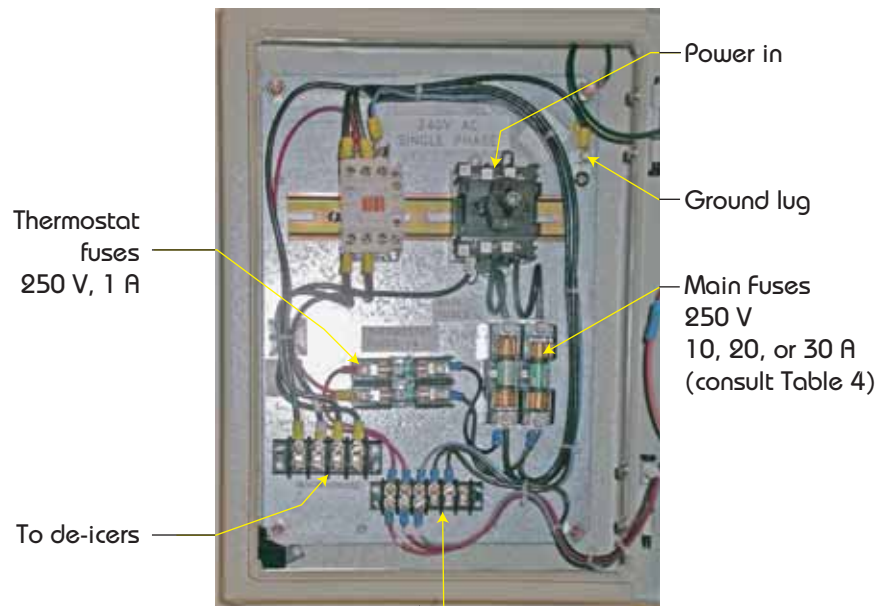

Removable panel - customer to drill and install connector

Cover open, not shown. Box dimensions are 300 mm (11.81 in) wide x 400 mm (15.75 in) high x 150 mm (5.90 in) deep.

Shively Model 94068 De-Icer Control Box

Check before powering up:

- a. Before connecting power to the system, measure the resistance across each heater leg. Be sure to account for the resistance of any long cable runs from the control box to the antenna. Compare readings against Table 1 in "Sizing of De-Icer Control Box and Wiring"
- b. Run a power cable from the main control box (normally indoors) to the tower junction box and connect it to the de-icer harness pigtail(s) in the tower junction box.
- c. After installation is complete, measure the resistance from each heater leg to ground to ensure that there are no short-circuits. Resistance should be infinite.
- d. Turn the de-icer on by switching it to Manual, and measure its current draw with an ammeter. Compare this reading with Table 2 in "Sizing of De-Icer Control Box and Wiring".

Log initial readings:

Record the resistance and current readings in your maintenance log for future reference in troubleshooting the de-icer system. See your antenna manual for a suggested log format.