

Installing the Shively Labs Model 55522-G502 Dual-Setting Thermostat

Description:

Rime ice will degrade your FM signal and must be prevented or quickly removed if it forms on your antenna. Rime ice tends to form at air temperatures between 10° and 38° F.

Below 10° F and above 38° F, rime ice is unlikely to form, and it is wasteful and expensive to operate your de-icers. In addition, at temperatures above 50° F, the de-icers may overheat and damage your antenna.

Therefore, the Shively Labs thermostat closes and actuates the de-icers only between 10° and 38° F.

Caveat:

NOTE

Shively Labs deicers are designed to prevent ice from forming on antenna elements and are not designed to melt ice that has already formed.

For this reason, Shively Labs recommends that the system be installed with a dual setting thermostat assembly (Shively Labs Model 55522-G502) and control box (Shively Labs Model 94068) to ensure that deicers are operated in the temperature range ice is most likely to form.

Precautions:

WARNING

Installation should be performed only by personnel experienced in RF systems, qualified in electric work, and familiar with this equipment.

The broadcast industry has recently recognized the potential medical hazards of intense radio frequency radiation. Don't expose personnel to personal harm. For reference, see CFR 29, Section 1910.97, the OSHA standard for exposure to non-ionizing radiation. Whenever a rigger is on the tower in the area of the antenna, shut off the transmitter and lock it off so that it cannot be turned on accidentally.

CAUTION

It is YOUR responsibility to ensure that your installation meets all applicable electrical codes. We recommend that the installation be reviewed by a qualified electrician before you apply power.

All parts of the de-icer system within about 20 feet (6 meters) of any radiator must be shielded from RF energy, and the entire outdoor portion of the system must be made waterproof.

Shively Labs's de-icer control box, Model 94068, is designed for interior installation only.

Installation information:

NOTE

Customer-supplied items are shown in broken lines.

Electric Power:

The de-icer system requires 220 VAC, 50 - 60 Hz., single-phase. Tables in "Sizing of De-Icer Control Box and Wiring" show approximate heater leg resistances and current draws, respectively, for various models and configurations.

Installation procedure

Locate the thermostat at your discretion. We recommend mounting it as closely as practical to the antenna.

CAUTION

When testing the thermostat, be sure one or both thermostat leads are disconnected before taking resistance readings. Otherwise, readings may be affected by other components.

Document No. [ts-thermostat_installation \(150323\)](#)

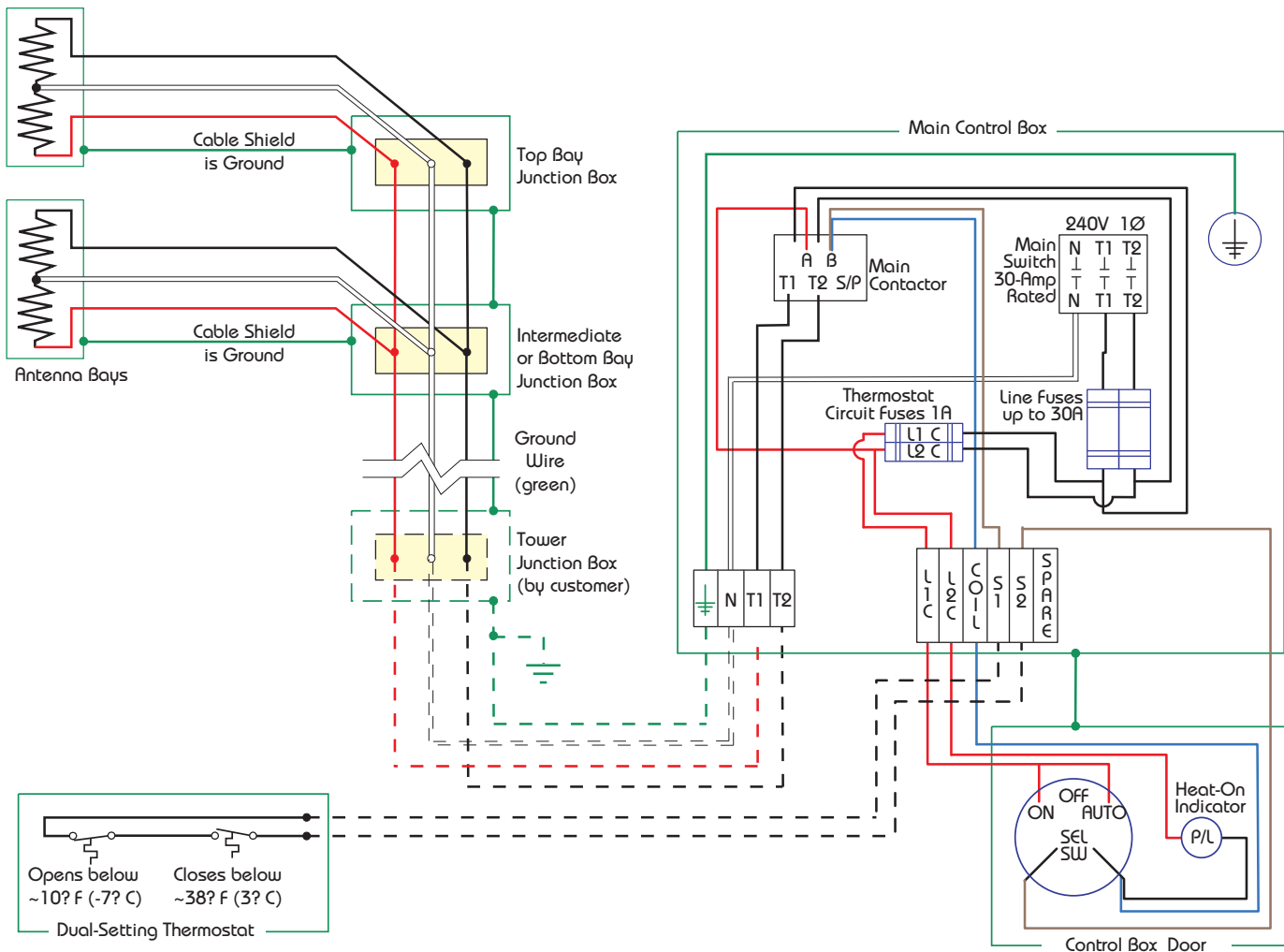

Figure 1. Electrical schematic diagram

NOTE

Shively recommends the use of shielded braided polyethylene-covered wire or rubber-sheathed flexible metal conduit or rigid conduit and weather-tight fittings at all junctions.

- a. Before you connect the thermostat, measure the resistance across the thermostat circuit and from it to ground to ensure that there are no short-circuits. Thermostat readings should be as shown in Table 1.

Table 1. Tandem Thermostat Readings

Reading Location	Ambient Temperature	Resistance = 0 ohms (short circuit)	Resistance = infinite ohms (open circuit)
Leg-to-Ground	Any	Defective thermostat or shorted leads	OK
leg-to-leg	Above about 38° F (3.3° C)	Defective thermostat or shorted leads	OK
	Between about 10° and about 38° F (-6.7° to 3.3° C)	OK	Defective thermostat or broken leads
	Below about 10° F (-6.7° C)	Defective thermostat or shorted leads	OK

- b. Mount the thermostat near the antenna and connect the thermostat leads to points S1 and S2 in the control box as shown in the schematic diagram.
- c. To prevent electrical short-circuiting, secure all cables to minimize wind-induced motion and chafing against edges of system or tower components.